

IB811F Series

**Intel® Pentium® / Celeron® /
Atom™ x7 / x5 SoC
3.5" Disk-Size SBC**

User's Manual

Version 1.4
(June 2018)

Copyright

© 2018 IBASE Technology, Inc. All rights reserved.

No part of this publication may be reproduced, copied, stored in a retrieval system, translated into any language or transmitted in any form or by any means, electronic, mechanical, photocopying, or otherwise, without the prior written consent of IBASE Technology, Inc. (hereinafter referred to as "IBASE").

Disclaimer

IBASE reserves the right to make changes and improvements to the products described in this document without prior notice. Every effort has been made to ensure the information in the document is correct; however, IBASE does not guarantee this document is error-free.

IBASE assumes no liability for incidental or consequential damages arising from misapplication or inability to use the product or the information contained herein, nor for any infringements of rights of third parties, which may result from its use.

Trademarks

All the trademarks, registrations and brands mentioned herein are used for identification purposes only and may be trademarks and/or registered trademarks of their respective owners.

Compliance



This product has passed CE tests for environmental specifications and limits. This product is in accordance with the directives of the European Union (EU). In a domestic environment, this product may cause radio interference in which case users may be required to take adequate measures.



This product has been tested and found to comply with the limits for a Class B device, pursuant to Part 15 of the FCC Rules. These limits are designed to provide reasonable protection against harmful interference in a residential installation. This equipment generates, uses and can radiate radio frequency energy and, if not installed and used in accordance with manufacturer's instructions, may cause harmful interference to radio communications.

WEEE



This product must not be disposed of as normal household waste, in accordance with the EU directive of for waste electrical and electronic equipment (WEEE - 2012/19/EU). Instead, it should be disposed of by returning it to a municipal recycling collection point. Check local regulations for disposal of electronic products.

Green IBASE



This product is compliant with the current RoHS restrictions and prohibits use of the following substances in concentrations exceeding 0.1% by weight (1000 ppm) except for cadmium, limited to 0.01% by weight (100 ppm).

- Lead (Pb)
- Mercury (Hg)
- Cadmium (Cd)
- Hexavalent chromium (Cr6+)
- Polybrominated biphenyls (PBB)
- Polybrominated diphenyl ether (PBDE)

Important Safety Information

Carefully read the precautions before using the board.

Environmental conditions:

- Use this product in environments with ambient temperatures between 0°C and 60°C, or -40 and 85 °C.
- Do not leave this product in an environment where the storage temperature may be below -40° C or above 110° C. To prevent from damages, the product must be used in a controlled environment.

Care for your iBASE products:

- Before cleaning the PCB, unplug all cables and remove the battery.
- Clean the PCB with a circuit board cleaner or degreaser, or use cotton swabs and alcohol.
- Vacuum the dust with a computer vacuum cleaner to prevent the fan from being clogged.



WARNING

Attention during use:

- Do not use this product near water.
- Do not spill water or any other liquids on this product.
- Do not place heavy objects on the top of this product.

Anti-static precautions

- Wear an anti-static wrist strap to avoid electrostatic discharge.
- Place the PCB on an anti-static kit or mat.
- Hold the edges of PCB when handling.
- Touch the edges of non-metallic components of the product instead of the surface of the PCB.
- Ground yourself by touching a grounded conductor or a grounded bit of metal frequently to discharge any static.



CAUTION

Danger of explosion if the internal lithium-ion battery is replaced by an incorrect type. Replace only with the same or equivalent type recommended by the manufacturer. Dispose of used batteries according to the manufacturer's instructions or recycle them at a local recycling facility or battery collection point.

Warranty Policy

- **IBASE standard products:**

24-month (2-year) warranty from the date of shipment. If the date of shipment cannot be ascertained, the product serial numbers can be used to determine the approximate shipping date.

- **3rd-party parts:**

12-month (1-year) warranty from delivery for the 3rd-party parts that are not manufactured by IBASE, such as CPU, CPU cooler, memory, storage devices, power adapter, panel and touchscreen.

- * PRODUCTS, HOWEVER, THAT FAIL DUE TO MISUSE, ACCIDENT, IMPROPER INSTALLATION OR UNAUTHORIZED REPAIR SHALL BE TREATED AS OUT OF WARRANTY AND CUSTOMERS SHALL BE BILLED FOR REPAIR AND SHIPPING CHARGES.

Technical Support & Services

1. Visit the IBASE website at www.ibase.com.tw to find the latest information about the product.
2. If you need any further assistance from your distributor or sales representative, prepare the following information of your product and elaborate upon the problem.
 - Product model name
 - Product serial number
 - Detailed description of the problem
 - The error messages in text or in screenshots if there is any
 - The arrangement of the peripherals
 - Software in use (such as OS and application software, including the version numbers)
3. If repair service is required, you can download the RMA form at <http://www.ibase.com.tw/english/Supports/RMAService/>. Fill out the form and contact your distributor or sales representative.

Table of Contents

Compliance	iii
Important Safety Information	iv
Warranty Policy	v
Technical Support & Services	v
Chapter 1 General Information	1
1.1 Introduction	2
1.2 Features	2
1.3 Packing List	3
1.4 Optional Accessories	3
1.5 Specifications	4
1.6 Block Diagram	7
1.7 Overview	8
1.8 Dimensions	10
Chapter 2 Hardware Configuration	11
2.1 Essential Installations Before You Begin	12
2.1.1 Installing the Memory	12
2.2 Setting the Jumpers	13
2.2.1 How to Set Jumpers	13
2.3 Jumper & Connector Locations	14
2.4 Jumpers Quick Reference	15
2.4.1 LVDS Panel Brightness Selection (JP1)	15
2.4.2 LVDS Panel Power Selection (JP2)	16
2.4.3 eDP Panel Power Selection (JP3)	16
2.4.4 eDP / LVDS Panel Selection (JP4)	17
2.4.5 ATX / AT Power Selection (JP5)	17
2.4.6 CMOS Data Clearance (JP6)	18
2.4.7 ME Register Clearance (JP7)	18
2.5 Connectors Quick Reference	19
2.5.1 eDP Connector (CN1)	20
2.5.2 SATA III Connector (CN2, CN3)	21
2.5.3 LAN Ports (CN4)	21
2.5.4 USB 3.0 Ports (CN5, CN6)	21

2.5.5	Console COM1 (RJ50) RS-232/422/485 Port (CN7)	22
2.5.6	DisplayPort (CN8).....	23
2.5.7	HDMI Port (CN9)	23
2.5.8	LCD Backlight Connector (J2)	23
2.5.9	LVDS Connector (J1, J3).....	24
2.5.10	Audio Connector (J4).....	25
2.5.11	DDR3L SO-DIMM Slot (J5, J8).....	25
2.5.12	USB 2.0 Connector (J6).....	26
2.5.13	Amplifier Connector (J7)	26
2.5.14	SATA HDD Power Connector (J10)	27
2.5.15	Mini PCIe / mSATA Slot (J11)	27
2.5.16	COM2 / COM3 / COM4 RS-232 Port (J16, J17, J12).....	28
2.5.17	M.2 (B key) 3042 Slot (J14)	28
2.5.18	Front Panel Connector (J13).....	29
2.5.19	Digital I/O Connector (J18)	30
2.5.20	DC Power Input Connector (J19)	30

Chapter 3 Drivers Installation 31

3.1	Introduction.....	32
3.2	Intel® Chipset Software Installation Utility	33
3.3	VGA Driver Installation.....	35
3.4	HD Audio Driver Installation	37
3.5	Intel® Trusted Execution Engine Drivers	39
3.6	Intel® Serial IO Drivers	41
3.7	LAN Driver Installation	43

Chapter 4 BIOS Setup..... 45

4.1	Introduction.....	46
4.2	BIOS Setup.....	46
4.3	Main Settings.....	48
4.4	Advanced Settings.....	49
4.4.1	ACPI Computing.....	50
4.4.2	LVDS (eDP/DP) Configuration.....	51
4.4.3	Fintek Super IO Configuration	52
4.4.4	Fintek Super IO Hardware Monitor.....	54
4.4.5	M.2 Setup	55
4.4.6	CPU Configuration.....	56
4.4.7	AMI Graphic Output Protocol Policy.....	57
4.4.8	Network Stack Configuration	58

iBASE

4.4.9	CSM Configuration	59
4.4.10	USB Configuration	60
4.5	Chipset Settings	61
4.5.1	North Bridge	61
4.5.2	South Cluster Configuration	62
4.6	Security Settings	67
4.7	Boot Settings	68
4.8	Save & Exit Settings	69
Appendix		70
A.	I/O Port Address Map	71
B.	Interrupt Request Lines (IRQ)	74
C.	Watchdog Timer Configuration	76
D.	Onboard Connector Types	80

Chapter 1

General Information

The information provided in this chapter includes:

- Features
- Packing List
- Block Diagram
- Specifications
- Board Overview
- Board Dimensions

1.1 Introduction

IB811F is a 3.5" disk-size single board computer based on the platform of Intel® Atom™ x7/x5, Pentium® or Celeron®. It features both DisplayPort and HDMI at coastline, and onboard headers for eDP / 24-bit dual channel LVDS interfaces for video display. It can be operated at the ambient operating temperature ranging from 0 ~ 60 °C, and even from -40 ~ 85 °C for models of wide temperature.



Photo of IB811F-420

1.2 Features

- 3.5" disk-size SBC with Intel® Atom™ x7-E3950 / x5-E3930 / Pentium® N4200 / Celeron® N3350
- 2 x DDR3L-1600/1866 SO-DIMM slots, expandable up to 16GB
- 1 x HDMI, 1 x DisplayPort, eDP / 24 bit dual channel LVDS
- 2 x GbE LAN, 4 x USB 3.0, 2 x USB 2.0, 4 x COM, 2 x SATA III, 1 x Mini PCIe slot (full-size), 1 x M.2 (B-key)
- Configurable watchdog timer and digital I/O, mSATA, EuP/ErP
- Wide temperature supported by IB811F-I50 and IB811F-I30

1.3 Packing List

Your IB811F package should include the items listed below. If any of the items below is missing, contact the distributor or dealer from whom you purchased the product.

- IB811F SBC x 1
- Disk x 1
(including chipset drivers and flash memory utility)
- This User's Manual x 1

1.4 Optional Accessories

IBASE provides optional accessories as follows. Please contact us or your dealer if you need any.

- Cable Kit (IB76A)
(including:

SATA cable (SATA-53)	x 1
Power cable (PW87)	x 1
COM ports cable (PK1H)	x 1
USB cable (USB29)	x 1
- Heatsink for IB811F-I50 / IB811F-I30 (HSIB811-A)
- Heatsink for IB811F-420 / IB811F-335 (HSIB811-B)
- Audio cable (Audio-18)
- COM1 RJ50 Cable (PK105)

1.5 Specifications

Product Name	IB811F-I50	IB811F-I30	IB811F-420	IB811F-335
Form Factor	3.5" disk-size SBC			
System				
Operating System	<ul style="list-style-type: none"> • Windows 10 Enterprise (64-bit) • Windows 10 IoT Core (64-bit) • Linux Ubuntu 			
CPU Type	Intel® Atom™ QC x7 / E3950	Intel® Atom™ DC x5 / E3930	Intel® Pentium® QC N4200	Intel® Celeron® DC N3350
CPU Speed	1.6 ~ 2.0 GHz	1.3 ~ 1.8 GHz	1.1 ~ 2.5 GHz	1.1 ~ 2.4 GHz
Cache	2 MB			
Chipset	Integrated			
Memory	2 x DDR3L-1600/1866 SO-DIMM, expandable up to 16 GB (Non-ECC)			
Storage	1 x mSATA SSD			
Graphics	Intel® SoC integrated Gen. 9			
Network	2 x Intel® I210IT PCIe Gigabit Ethernet		2 x Intel® I211AT PCIe Gigabit Ethernet	
Super I/O	Fintek F81964			
Audio Codec & Controller	Intel® SoC built-in HD audio controller Realtek ALC283QHD codec with speaker amplifier			
Power Requirement	9 ~ 36V DC-In (jumper-selectable ATX / AT power mode)			
Watchdog Timer	Yes (256 segments, 0, 1, 2...255 sec / min)			
BIOS	AMI BIOS			
H/W Monitor	Yes			

Product Name	IB811F-I50	IB811F-I30	IB811F-420	IB811F-335
Smart Control	<ul style="list-style-type: none"> • EuP/ErP • Power failure detection by a jumper connector • LVDS brightness control 			
Dimensions	102.22 x 147.01 mm (4.02" x 5.8")			
RoHS	Yes			
Certification	CE, FCC Class B			
I/O Ports				
Display	<ul style="list-style-type: none"> • 1 x HDMI (1.4b), 3840 x 2160 at 30 Hz • 1 x DisplayPort (1.2), 4096 x 2160 at 60 Hz • 1 x eDP / 24-bit dual channel LVDS eDP: 1920 x 1080 at 60 Hz LVDS: 1920 x 1200 at 60 Hz 			
LAN	2 x RJ45 GbE LAN			
USB	<ul style="list-style-type: none"> • 4 x USB 3.0: I/O coastline connectors • 2 x USB 2.0: via an onboard pin headers 			
Serial	4 x COM ports: <ul style="list-style-type: none"> • COM1: RS-232/422/485 (I/O coastline RJ50 connector, jumper-less selection) • COM2, COM3, COM4: RS-232 only (via onboard box-headers) 			
SATA	2 x SATA III			
Audio	Onboard audio connector for Line-In, Line-Out, and Mic-In			
Digital IO	4-In & 4-Out			
Expansion Slots	<ul style="list-style-type: none"> • 1 x Mini PCIe slot (full-size) with USB and mSATA • 1 x M.2 (B key) 3042 Slot with PCIe (x1), USB and SATA 			

Product Name	IB811F-I50	IB811F-I30	IB811F-420	IB811F-335
Environment				
Temperature	<ul style="list-style-type: none">• Operation: -40 ~ 85 °C (-40 ~ 185 °F)• Storage: -40 ~ 110 °C (-40 ~ 230 °F)		<ul style="list-style-type: none">• Operation: 0 ~ 60 °C (32 ~ 140 °F)• Storage: -40 ~ 110 °C (-40 ~ 230 °F)	
Relative Humidity	0 ~ 90 %, non-condensing at 60 °C			

All specifications are subject to change without prior notice.

1.6 Block Diagram

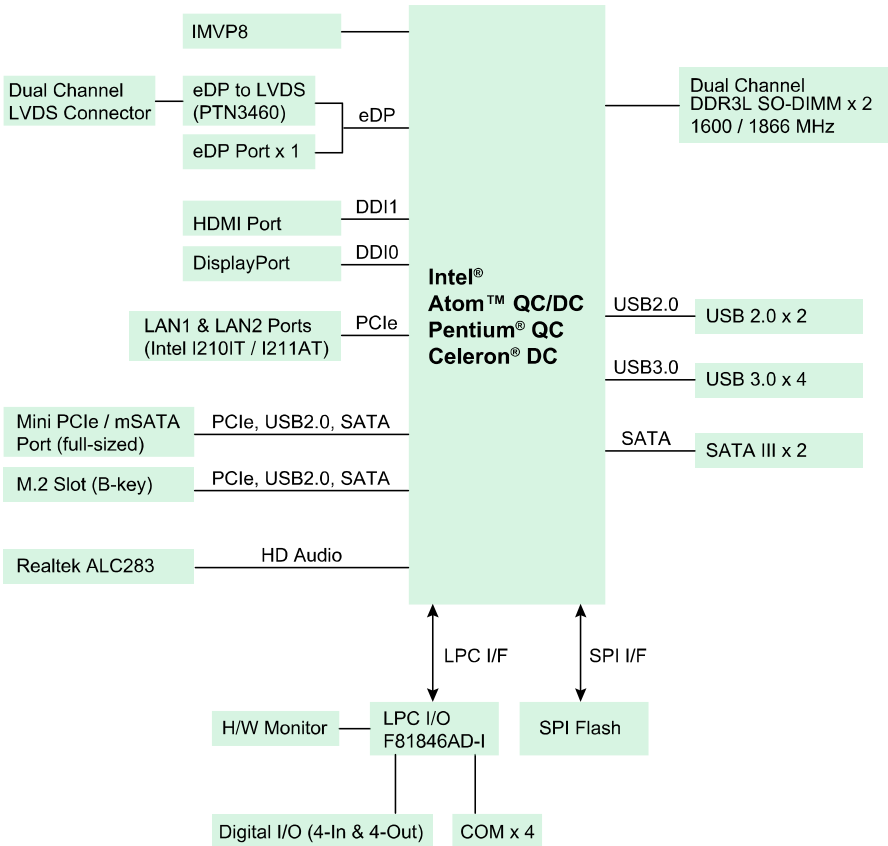

1.7 Overview

Top View



Bottom View



Photo of IB811F-420

* The photos above are for reference only. Some minor components may differ.

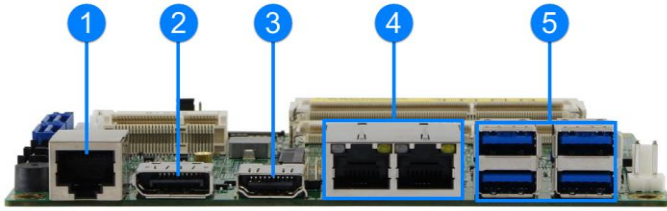
I/O View

No.	Name	No.	Name
1	COM1 (RJ50) Port	4	LAN Port
2	DisplayPort	5	USB 3.0 Port
3	HDMI Port		

1.8 Dimensions

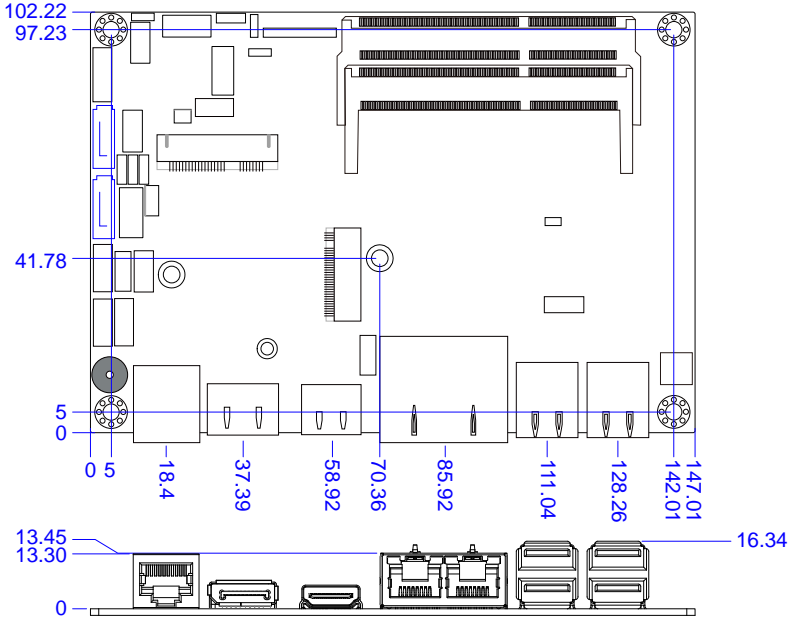

Chapter 2

Hardware Configuration

This section provides information on jumper settings and connectors on the IB811F in order to set up a workable system. On top of that, you will also need to install crucial pieces such as the CPU and the memory before using the product. The topics covered are:

- Essential installations before you begin:
CPU and the memory
- Jumper and connector locations
- Jumper settings and information of connectors

2.1 Essential Installations Before You Begin

Follow the instructions below to install the memory.

2.1.1 Installing the Memory

To install the modules, locate the memory slot on the board and perform the following steps:

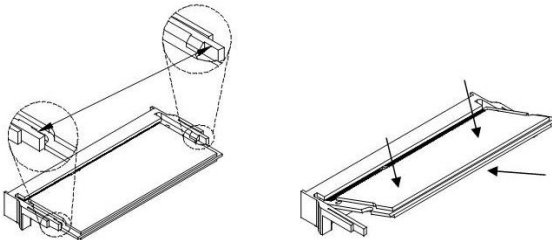

1. Align the key of the memory module with that on the memory slot and insert the module slantwise.
2. Gently push the module in an upright position until the clips of the slot close to hold the module in place when the module touches the bottom of the slot.

To remove the module, press the clips outwards with both hands, and the module will pop-up.

2.2 Setting the Jumpers

Set up and configure your IB811F by using jumpers for various settings and features according to your needs and applications. Contact your supplier if you have doubts about the best configuration for your use.

2.2.1 How to Set Jumpers

Jumpers are short-length conductors consisting of several metal pins with a non-conductive base mounted on the circuit board. Jumper caps are used to have the functions and features enabled or disabled. If a jumper has 3 pins, you can connect either PIN1 to PIN2 or PIN2 to PIN3 by shorting.

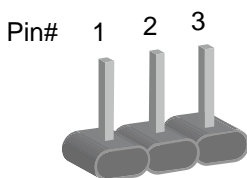

A 3-pin jumper

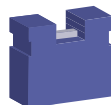

A jumper cap

Refer to the illustration below to set jumpers.

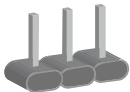
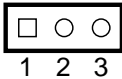
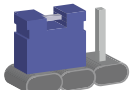
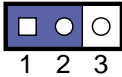
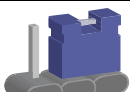
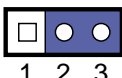
Pin closed	Oblique view	Schematic illustration in the manual
Open		 1 2 3
1-2		 1 2 3
2-3		 1 2 3

When two pins of a jumper are encased in a jumper cap, this jumper is **closed**, i.e. turned **On**.

When a jumper cap is removed from two jumper pins, this jumper is **open**, i.e. turned **Off**.

2.3 Jumper & Connector Locations

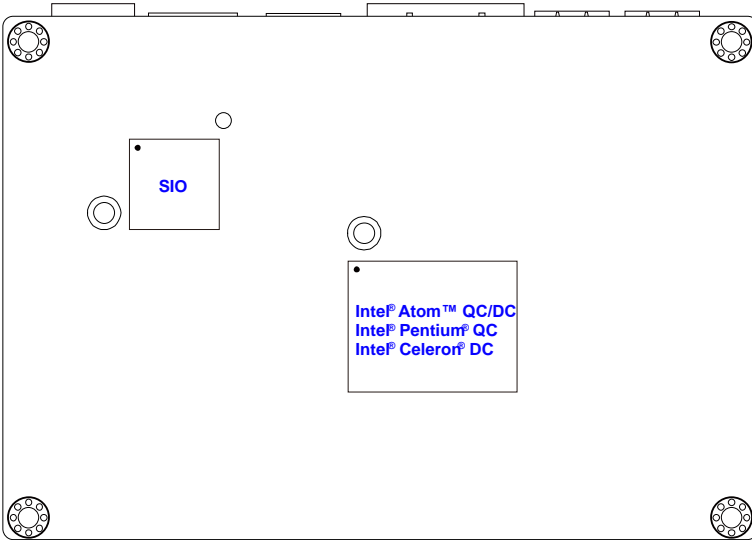
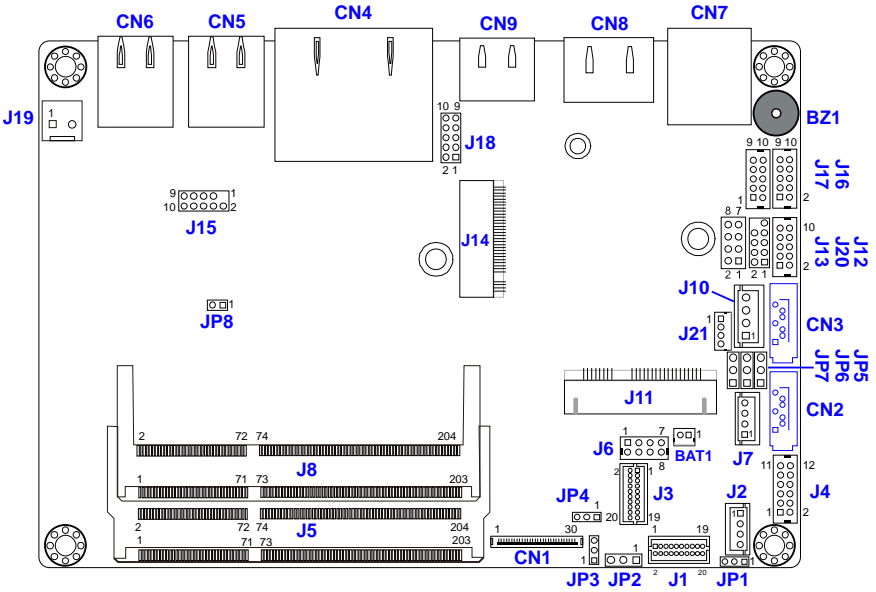

Board diagram of IB811F

2.4 Jumpers Quick Reference

Function	Jumper Name	Page
LCD Panel Brightness Selection	JP1	15
LVDS Panel Power Selection	JP2	16
eDP Panel Power Selection	JP3	16
eDP / LVDS Panel Selection	JP4	17
ATX / AT Power Selection	JP5	17
CMOS Data Clearance	JP6	18
ME Register Clearance	JP7	18
Factory Use Only	JP8	--

2.4.1 LVDS Panel Brightness Selection (JP1)

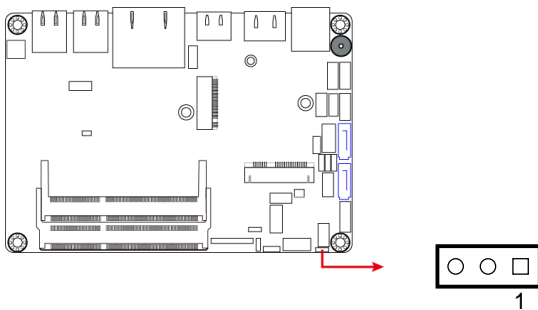

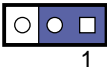
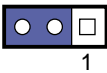
Function	Pin closed	Illustration
3.3V (default)	1-2	
5V	2-3	

2.4.2 LVDS Panel Power Selection (JP2)

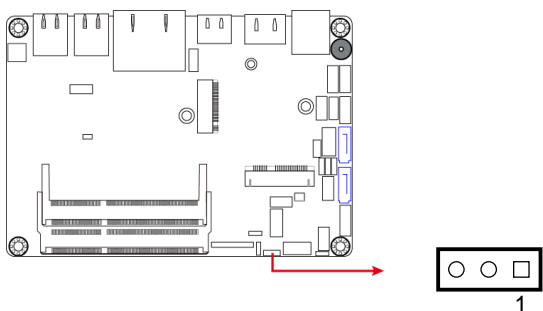

Function	Pin closed	Illustration
3.3V (default)	1-2	1
5V	2-3	1

2.4.3 eDP Panel Power Selection (JP3)

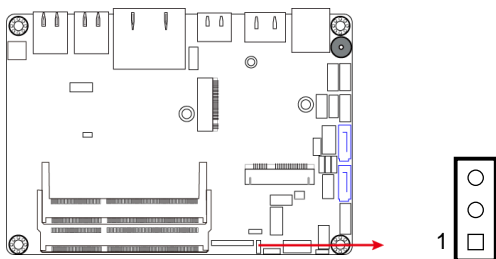

Function	Pin closed	Illustration
3.3V (default)	1-2	1
5V	2-3	1

2.4.4 eDP / LVDS Panel Selection (JP4)

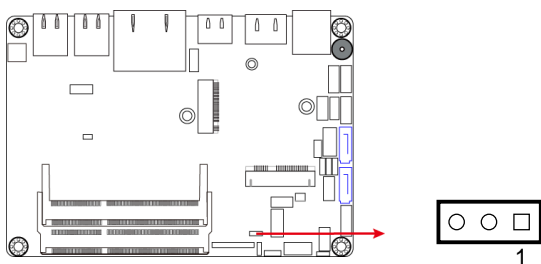

Function	Pin closed	Illustration
eDP	1-2	
LVDS (default)	2-3	

2.4.5 ATX / AT Power Selection (JP5)

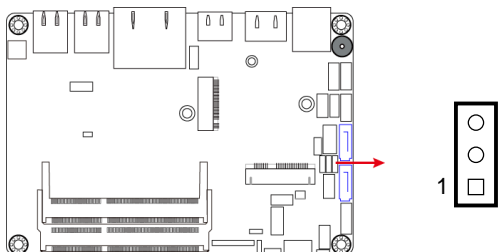

Function	Pin closed	Illustration
ATX (default)	1-2	
AT	2-3	

2.4.6 CMOS Data Clearance (JP6)

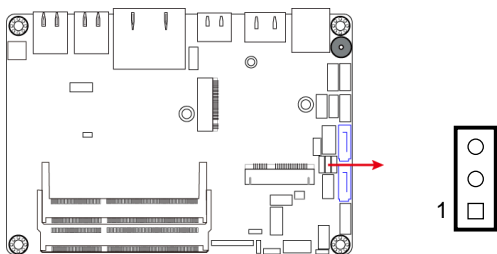

Function	Pin closed	Illustration
Normal (default)	1-2	
Clear CMOS	2-3	

2.4.7 ME Register Clearance (JP7)

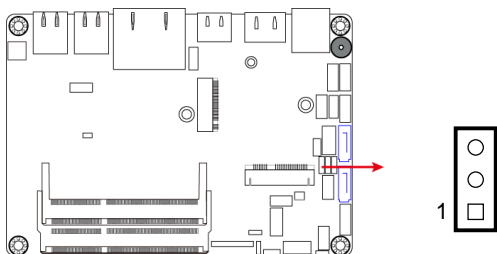

Function	Pin closed	Illustration
Normal (default)	1-2	
Clear ME	2-3	

2.5 Connectors Quick Reference

Function	Connector Name	Page
eDP Connector	CN1	20
SATA III Connector	CN2 (shared with M.2 B-key) CN3 (shared with mSATA)	21
LAN Ports	CN4	21
USB 3.0 Ports	CN5, CN6	21
Console COM1 (RJ50) RS-232/422/485 Port	CN7	22
DisplayPort	CN8	23
HDMI Port	CN9	23
LCD Backlight Connector	J2	23
LVDS Connector	J1, J3	24
Audio Connector	J4	25
DDR3L SO-DIMM Slot	J5, J8	25
USB 2.0 Connector	J6	26
Amplifier Connector	J7	26
SATA HDD Power Connector	J10	27
Mini PCIe / mSATA Slot	J11	27
COM2 / COM3 / COM4 RS-232 Port	J16, J17, J12	28
M.2 (B key) 3042 Slot	J14	28
Front Panel Connector	J13	29
Digital I/O Connector	J18	30
DC Power Input Connector	J19	30
Factory Use Only	J15, J20, J21	--

2.5.1 eDP Connector (CN1)

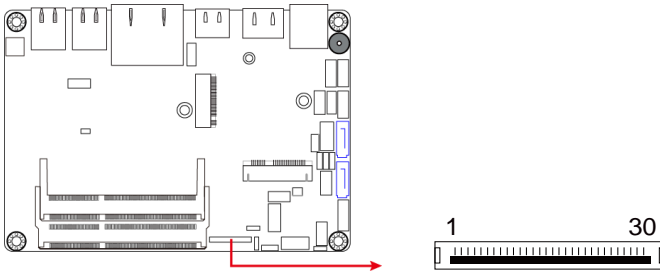

Pin	Assignment	Pin	Assignment
1	NC	16	Ground
2	BL_Power	17	NC
3	BL_Power	18	Panel_VDD
4	BL_Power	19	Panel_VDD
5	BL_Power	20	Ground
6	NC	21	AUX_N
7	NC	22	AUX_P
8	BRIGHTNESS	23	Ground
9	Bklt_en	24	TX0_P
10	Ground	25	TX0_N
11	Ground	26	Ground
12	Ground	27	TX1_P
13	Ground	28	TX1_N
14	HPD	29	Ground
15	Ground	30	NC

2.5.2 SATA III Connector (CN2, CN3)

CN2: shared with M.2 B-key

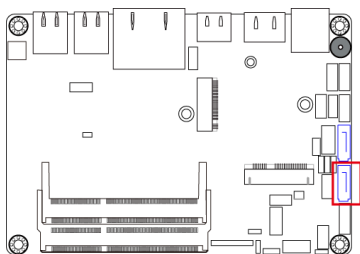

CN3: shared with mSATA

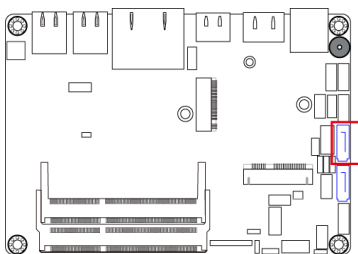

2.5.3 LAN Ports (CN4)

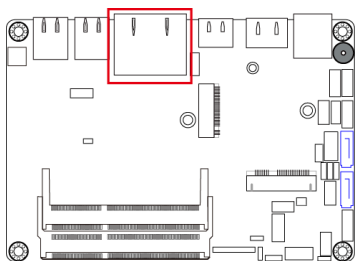

2.5.4 USB 3.0 Ports (CN5, CN6)

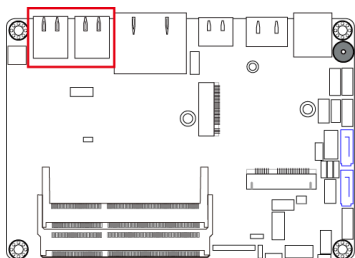

2.5.5 Console COM1 (RJ50) RS-232/422/485 Port (CN7)

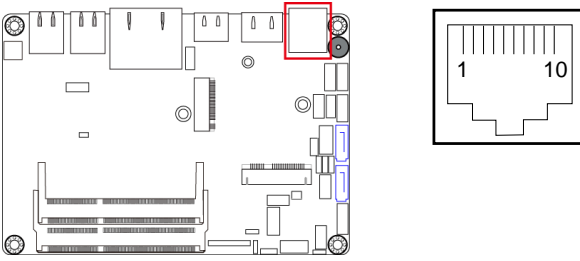

COM1 port is jumper-less and configurable in BIOS.

Pin	Assignment	Pin	Assignment
1	DSR, Data set ready	6	DCD, Data carrier detect
2	Ground	7	DTR, Data terminal ready
3	Ground	8	CTS, Clear to send
4	TX, Transmit	9	RTS, Request to send
5	RX, Receive	10	RI, Ring Indicator

Pin	Assignment		
	RS-232	RS-422	RS-485
1	DSR	NC	NC
2	Ground	Ground	Ground
3	Ground	Ground	Ground
4	TX	RX+	NC
5	RX	TX+	Data+
6	DCD	TX-	Data-
7	DTR	RX-	NC
8	CTS	NC	NC
9	RTS	NC	NC
10	RI	NC	NC

2.5.6 DisplayPort (CN8)

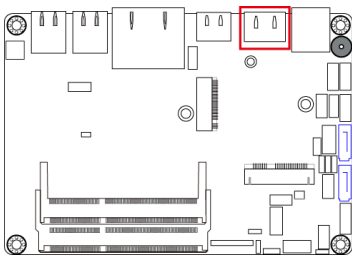

2.5.7 HDMI Port (CN9)

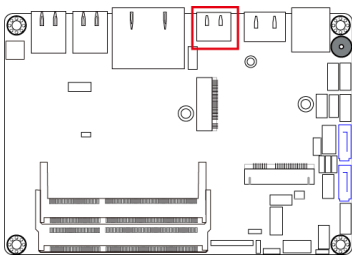

2.5.8 LCD Backlight Connector (J2)

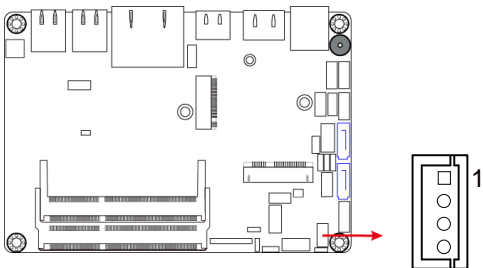

Pin	Assignment	Pin	Assignment
1	+12V	3	Brightness Control
2	Backlight Enable	4	Ground

2.5.9 LVDS Connector (J1, J3)

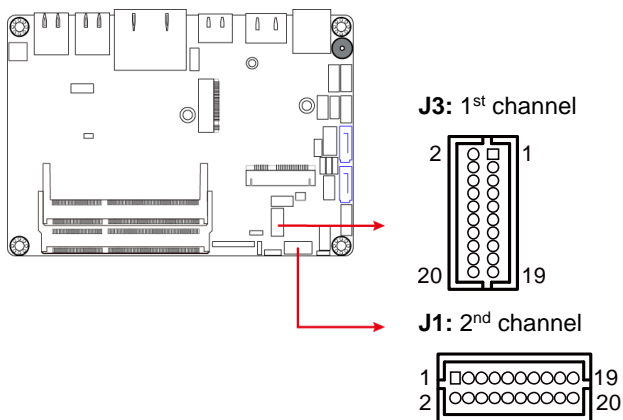

Pin	Assignment	Pin	Assignment
1	TX0P	2	TX0N
3	Ground	4	Ground
5	TX1P	6	TX1N
7	Ground	8	Ground
9	TX2P	10	TX2N
11	Ground	12	Ground
13	CLKP	14	CLKN
15	Ground	16	Ground
17	TX3P	18	TX3N
19	VDD	20	VDD

2.5.10 Audio Connector (J4)

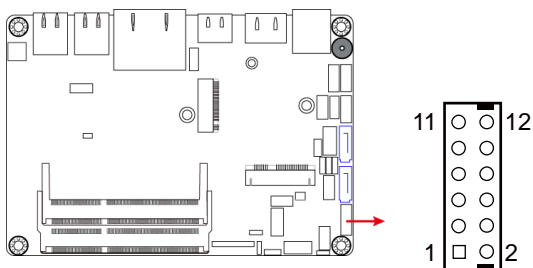

Pin	Assignment	Pin	Assignment
1	Lineout_L	2	Lineout_R
3	JD_FRONT	4	Ground
5	LINEIN_L	6	Linein_R
7	JD_LINEIN	8	Ground
9	MIC_L	10	MIC-R
11	JD_MIC1	12	Ground

2.5.11 DDR3L SO-DIMM Slot (J5, J8)

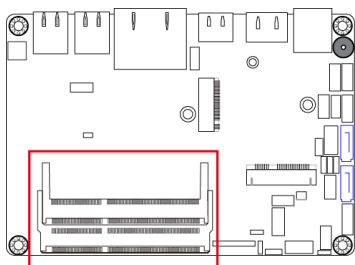

2.5.12 USB 2.0 Connector (J6)

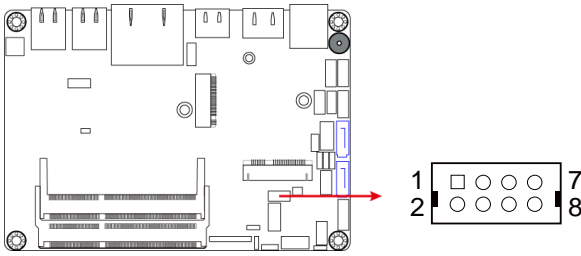

Pin	Assignment	Pin	Assignment
1	VCC	2	Ground
3	D0-	4	D1+
5	D0+	6	D1-
7	Ground	8	VCC

2.5.13 Amplifier Connector (J7)

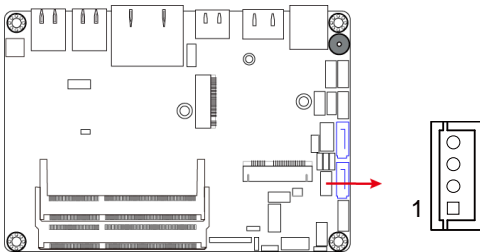

Pin	Assignment	Pin	Assignment
1	OUTL+	3	OUTR-
2	OUTL-	4	OUTR+

2.5.14 SATA HDD Power Connector (J10)

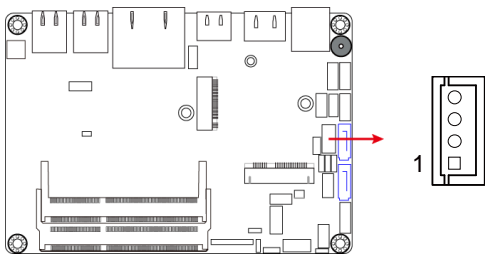

Pin	Assignment	Pin	Assignment
1	+5V	3	Ground
2	Ground	4	+12V

2.5.15 Mini PCIe / mSATA Slot (J11)

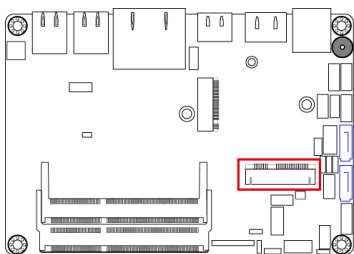

2.5.16 COM2 / COM3 / COM4 RS-232 Port (J16, J17, J12)

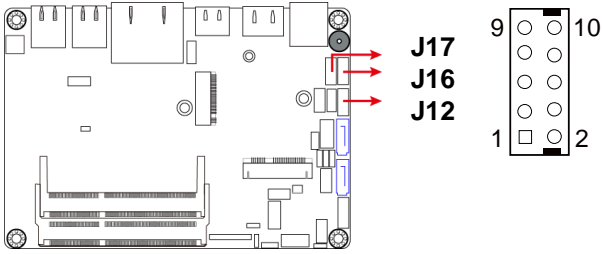

Pin	Assignment	Pin	Assignment
1	DCD, Data carrier detect	2	RXD, Receive data
3	TXD, Transmit data	4	DTR, Data terminal ready
5	Ground	6	DSR, Data set ready
7	RTS, Request to send	8	CTS, Clear to send
9	RI, Ring indicator	10	Not Used

2.5.17 M.2 (B key) 3042 Slot (J14)

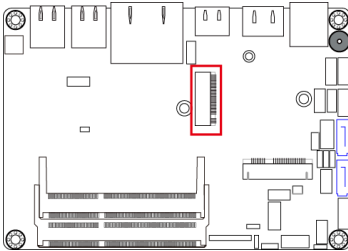

2.5.18 Front Panel Connector (J13)

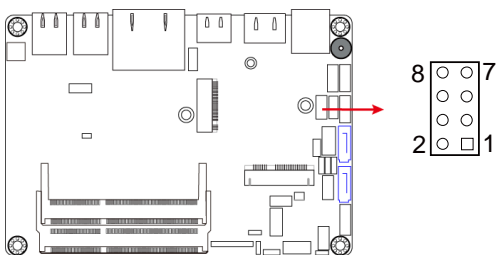

Pin	Assignment	Pin	Assignment
1	Ground	2	PWR_BTN
3	3.3V	4	HDD Active
5	Ground	6	Reset
7	+5V	8	Ground

J13 is utilized for system indicators to provide light indication of the computer activities and switches to change the computer status. It provides interfaces for the following functions.

- ATX Power ON Switch (Pins 1 and 2)**
 The 2 pins makes an “ATX Power Supply On/Off Switch” for the system that connects to the power switch on the case. When pressed, the power switch will force the system to power on. When pressed again, it will power off the system.
- Hard Disk Drive LED Connector (Pins 3 and 4)**
 This connector connects to the hard drive activity LED on control panel. This LED will flash when the HDD is being accessed.
- Reset Switch (Pins 5 and 6)**
 The reset switch allows you to reset the system without turning the main power switch off and then on again. Orientation is not required when making a connection to this header.
- Power LED: Pins 7 and 8**
 This connector connects to the system power LED on control panel. This LED will light when the system turns on.

2.5.19 Digital I/O Connector (J18)

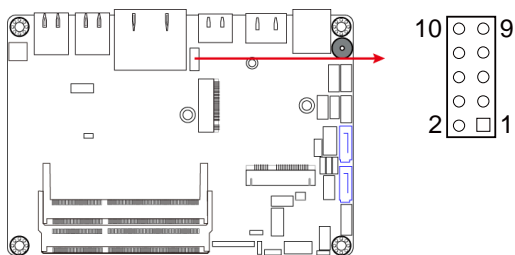

Pin	Assignment	Pin	Assignment
1	Ground	2	VCC
3	OUT3	4	OUT1
5	OUT2	6	OUT0
7	IN3	8	IN1
9	IN2	10	IN0

2.5.20 DC Power Input Connector (J19)

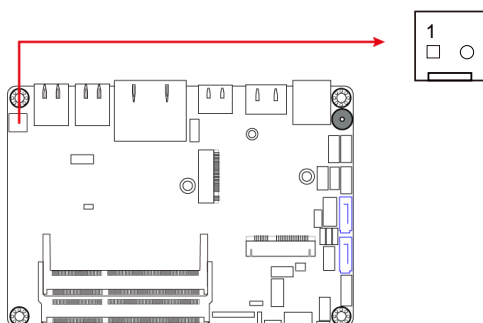

Pin	Assignment
1	+9V ~ +36V
2	Ground

Chapter 3

Drivers Installation

This chapter introduces installation of the following drivers:

- Intel® Chipset Software Installation Utility
- VGA Driver
- HD Audio Driver
- Intel® Trusted Execution Engine Installation
- LAN Driver

3.1 Introduction

This section describes the installation procedures for software and drivers. The software and drivers are included with the motherboard. If you find anything missing, please contact the distributor where you made the purchase. The contents of this section include the following:

Note: After installing your Windows operating system, you must install the Intel® Chipset Software Installation Utility first before proceeding with the drivers installation.

3.2 Intel® Chipset Software Installation Utility

The Intel® Chipset drivers should be installed first before the software drivers to install INF files for Plug & Play function for Intel chipset components. Follow the instructions below to complete the installation.

1. Insert the disk enclosed in the package with the board. Click **Intel** on the left pane and then **Intel(R) Apollolake Chipset Drivers** on the right pane.

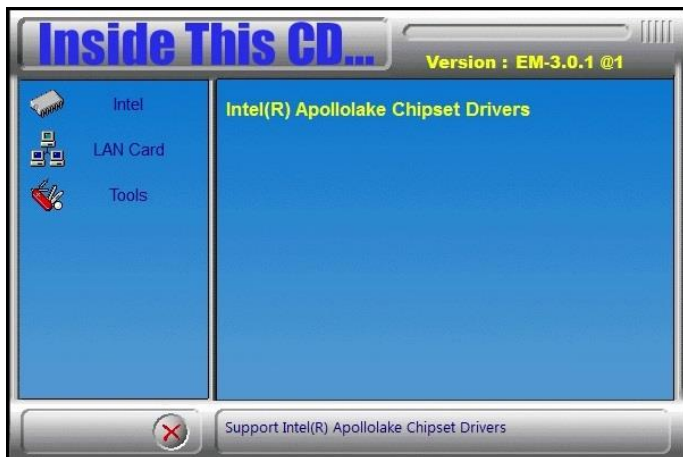

2. Click **Intel(R) Chipset Software Installation Utility**.



iBASE

3. When the *Welcome* screen to the Intel® Chipset Device Software appears, click **Next** to continue.
4. Click **Yes** to accept the software license agreement and proceed with the installation process.
5. On the *Readme File Information* screen, click **Install** for installation.

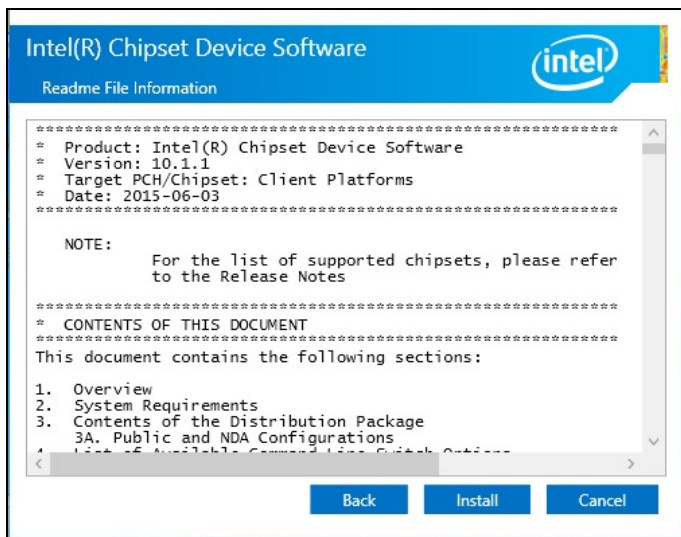

6. The driver has been completely installed. Restart the computer for changes to take effect.

3.3 VGA Driver Installation

1. Click **Intel** on the left pane and then **Intel(R) Apollolake Chipset Drivers** on the right pane.

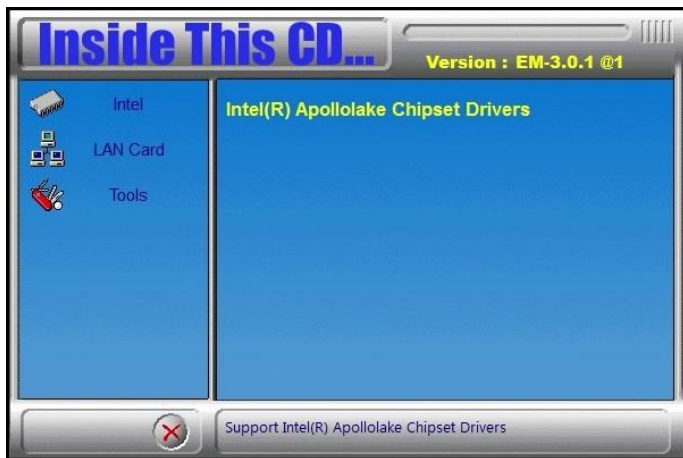

2. Click **Intel(R) Apollolake Graphics Driver**.



- When the the *Welcome* screen appears, click **Next** to continue.

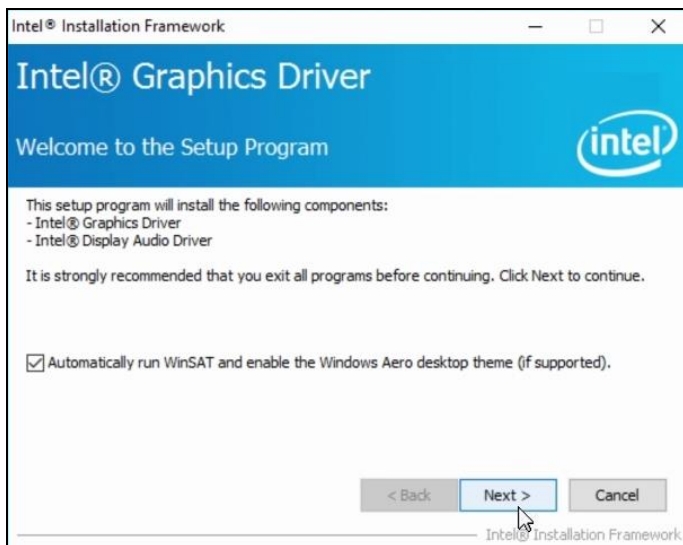

- Click **Yes** to accept the license agreement and click **Next** until the installation starts.
- The driver has been completely installed. Restart the computer for changes to take effect.

3.4 HD Audio Driver Installation

1. Click **Intel** on the left pane and then **Intel(R) Apollolake Chipset Drivers** on the right pane.

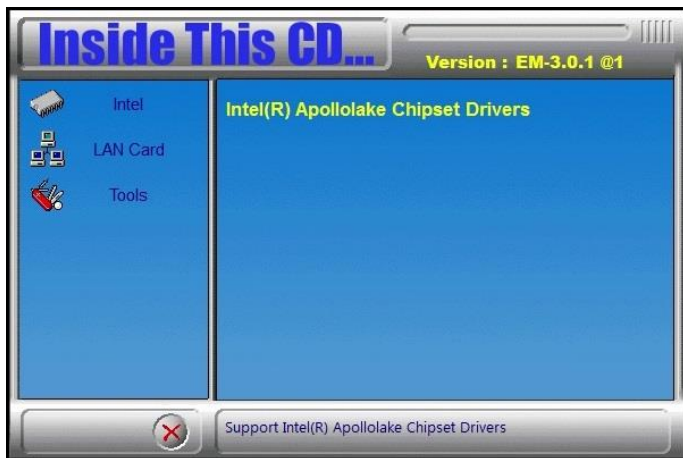

2. Click **Realtek High Definition Audio Driver**.



3. On the *Welcome* screen of the InstallShield Wizard, click **Next** for installation.

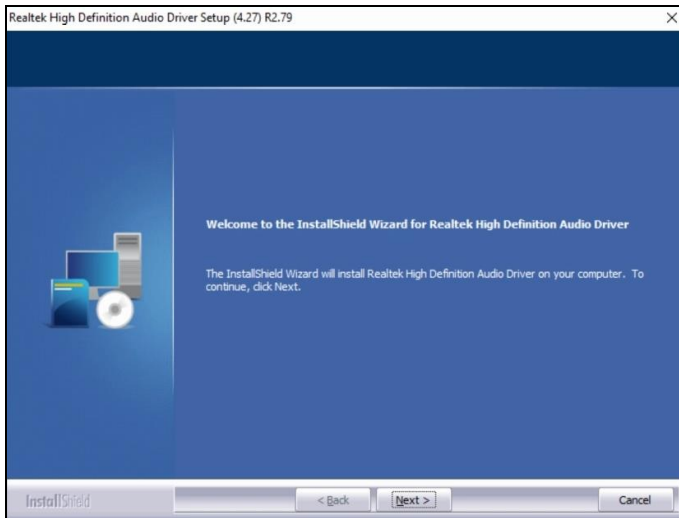

4. Click **Next** until the installation starts.
5. The driver has been completely installed. Restart the computer for changes to take effect.

3.5 Intel® Trusted Execution Engine Drivers

1. Click **Intel** on the left pane and then **Intel(R) Apollolake Chipset Drivers** on the right pane.

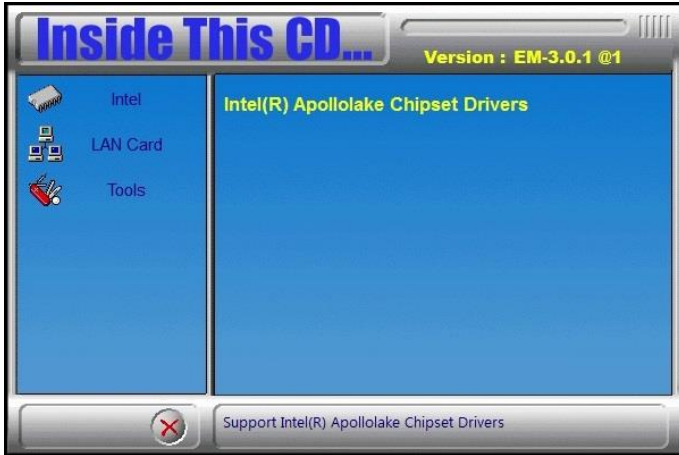

2. Click **Intel(R) TXE Drivers**.



- When the *Welcome* screen appears, click **Next**.

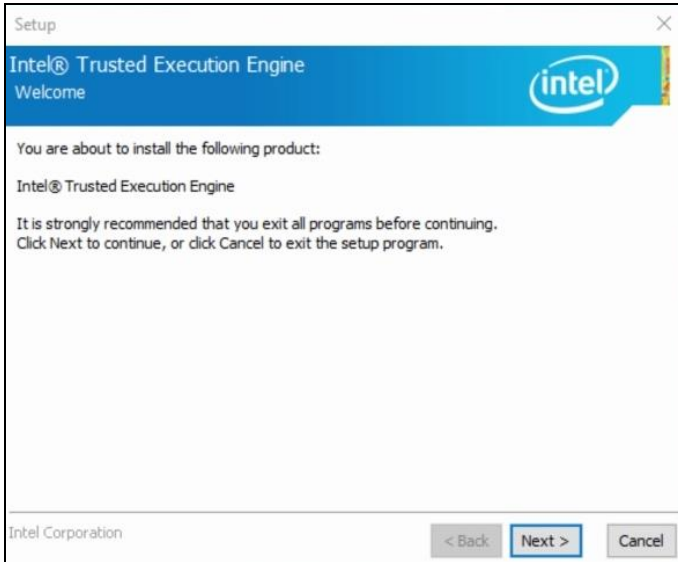

- Accept the license agreement and click **Next**.
- Click **Next** for installation.

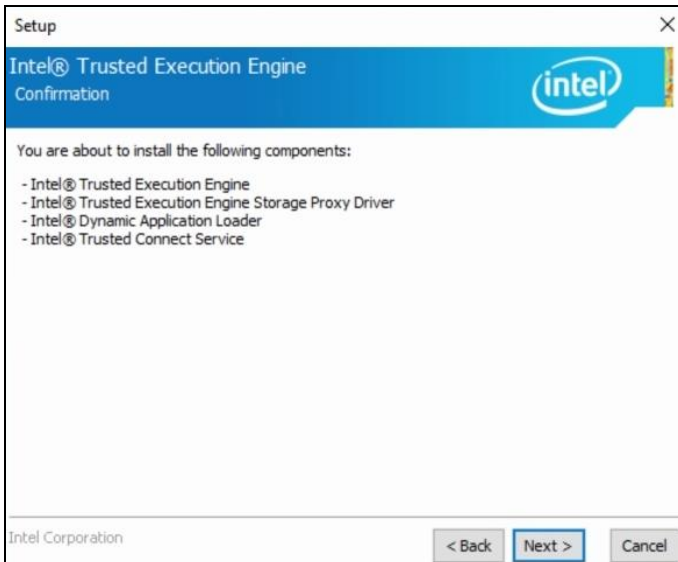

- As the driver has been successfully installed, restart the computer for changes to take effect.

3.6 Intel® Serial IO Drivers

1. Click **Intel** on the left pane and then **Intel(R) Apollolake Chipset Drivers** on the right pane.

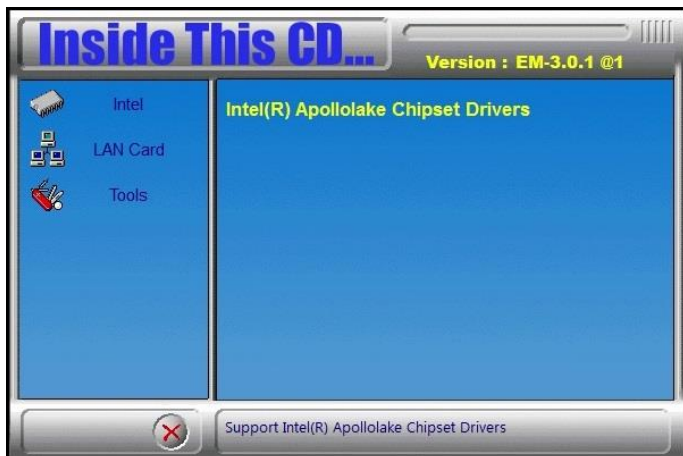

2. Click **Intel(R) Serial IO Drivers**.



- When the *Welcome* screen to the InstallShield Wizard appears, click **Next**.

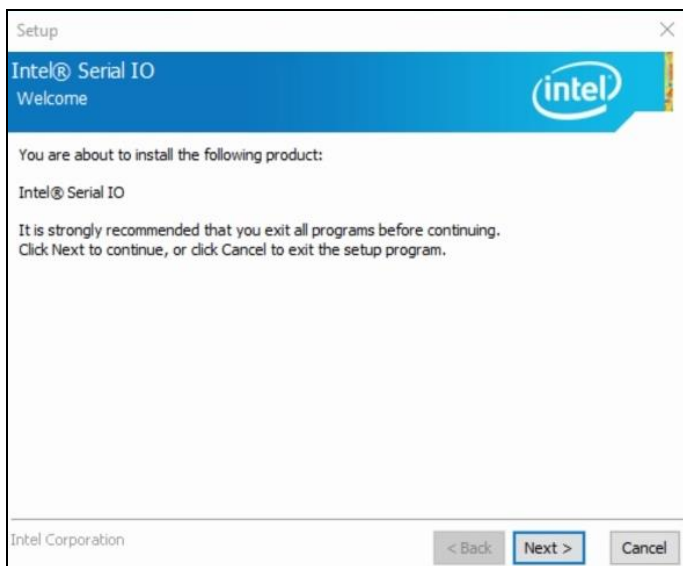

- Accept the license agreement and click **Next**.
- After reading the *Readme File Information*, click **Next** for installation.
- As the driver has been successfully installed, restart the computer for changes to take effect.

3.7 LAN Driver Installation

1. Click **LAN Card** on the left pane and then **Intel LAN Controller Drivers** on the right pane.



2. Click **Intel(R) I21x Gigabit Network Drivers..**

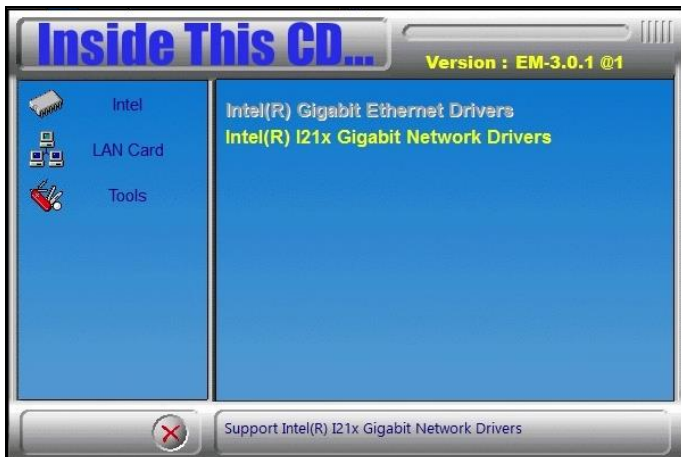

- When the *Welcome* screen appears, click **Next**.

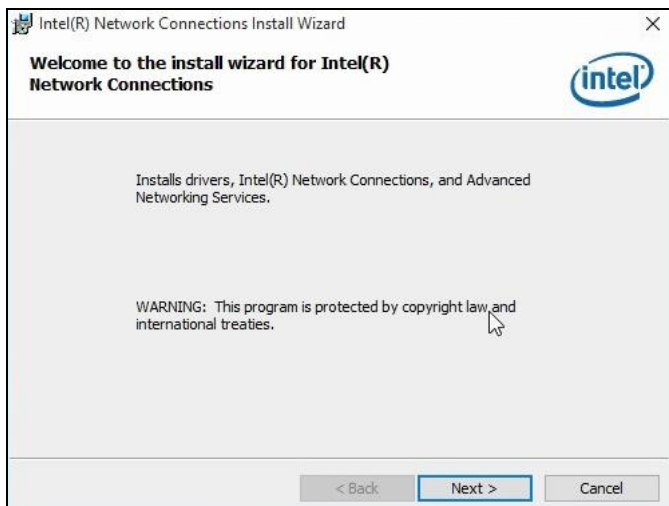

- Accept the license agreement and click **Next**.
- On the *Setup Options* screen, click the checkbox to select the desired driver(s) for installation. Then click **Next** to continue.

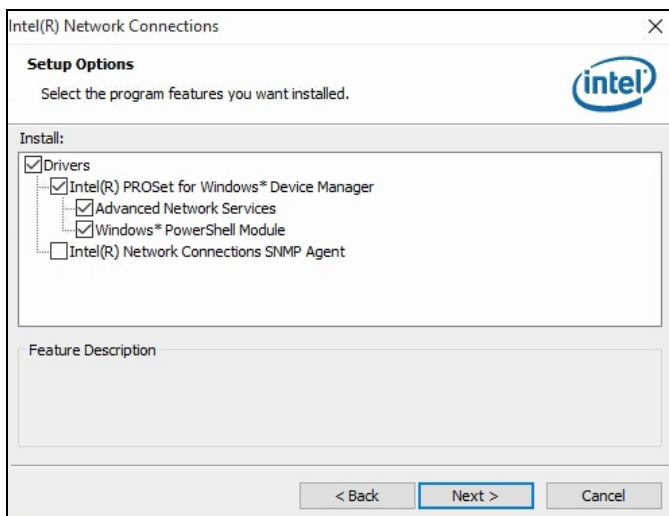

- The wizard is ready for installation. Click **Install**.
- As the installation is complete, restart the computer for changes to take effect.

Chapter 4

BIOS Setup

This chapter describes the different settings available in the AMI BIOS that comes with the board. The topics covered in this chapter are as follows:

- Main Settings
- Advanced Settings
- Chipset Settings
- Boot Settings
- Security Settings
- Save & Exit

4.1 Introduction

The BIOS (Basic Input/Output System) installed in the ROM of your computer system supports Intel® processors. The BIOS provides critical low-level support for standard devices such as disk drives, serial ports and parallel ports. It also provides password protection as well as special support for detailed fine-tuning of the chipset controlling the entire system.

4.2 BIOS Setup

The BIOS provides a Setup utility program for specifying the system configurations and settings. The BIOS ROM of the system stores the Setup utility. When you turn on the computer, the BIOS is immediately activated. Press the key immediately allows you to enter the Setup utility. If you are a little bit late pressing the key, POST (Power On Self Test) will continue with its test routines, thus preventing you from invoking the Setup.

If you still need to enter Setup, restart the system by pressing the "Reset" button or simultaneously pressing the <Ctrl>, <Alt> and <Delete> keys. You can also restart by turning the system Off and back On again.

The following message will appear on the screen:

```
Press <DEL> to Enter Setup
```

In general, press the arrow keys to highlight items, <Enter> to select, the <PgUp> and <PgDn> keys to change entries, <F1> for help, and <Esc> to quit.

When you enter the BIOS Setup utility, the *Main Menu* screen will appear on the screen. The Main Menu allows you to select from various setup functions and exit choices.

Warning: It is strongly recommended that you avoid making any changes to the chipset defaults.

These defaults have been carefully chosen by both AMI and your system manufacturer to provide the absolute maximum performance and reliability. Changing the defaults could make the system unstable and crash in some cases.

4.3 Main Settings

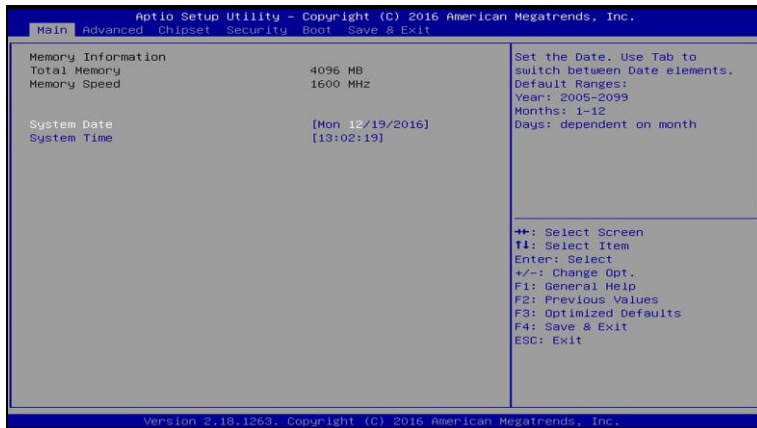

BIOS Setting	Description
System Date	Sets the date. Use the <Tab> key to switch between the data elements.
System Time	Set the time. Use the <Tab> key to switch between the data elements.

4.4 Advanced Settings

This section allows you to configure, improve your system and allows you to set up some system features according to your preference.

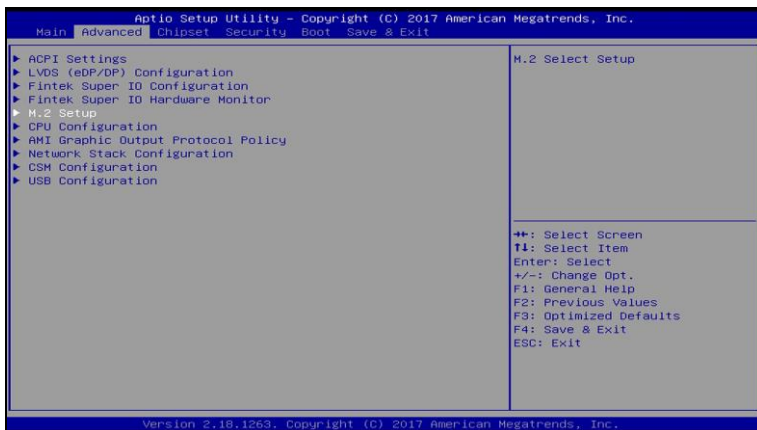

4.4.1 ACPI Computing

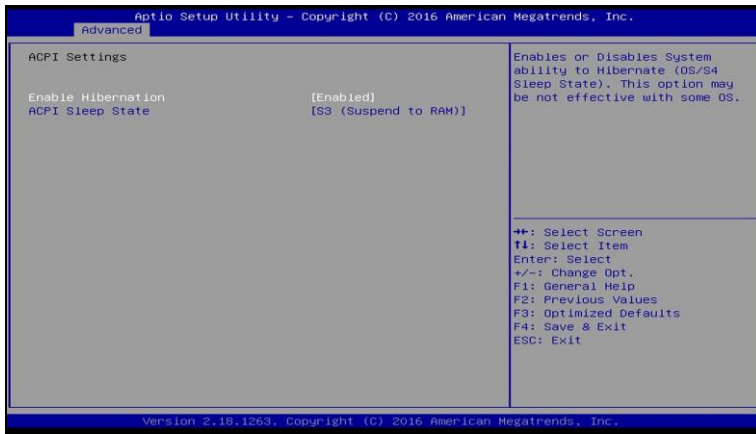

BIOS Setting	Description
Enable Hibernation	Enables / Disables the system ability to hibernate (OS/S4 Sleep State). This option may be not effective with some OS.
ACPI Sleep State	Selects an ACPI sleep state (Suspend Disabled or S3) where the system will enter when the Suspend button is pressed.

4.4.2 LVDS (eDP/DP) Configuration



BIOS Setting	Description
LVDS (eDP/DP) Support	Enables / Disables LVDS (eDP/DP)
Panel Color Depth	Selects a panel color depth as 18 or 24 (VESA or JEIDA) bit.
LVDS Channel Type	Sets the LVDS channel type as single or dual channel.
Panel Type	Selects a resolution that fits your panel. Options: 800 x 600 / 1024 x 768 / 1280 x 1024 / 1366 x 768 / 1440 x 900 / 1600 x 900 / 1920 x 1080
LVDS Backlight Level Control	Selects from Level 1 to Level 8 for the LVDS backlight.

4.4.3 Fintek Super IO Configuration

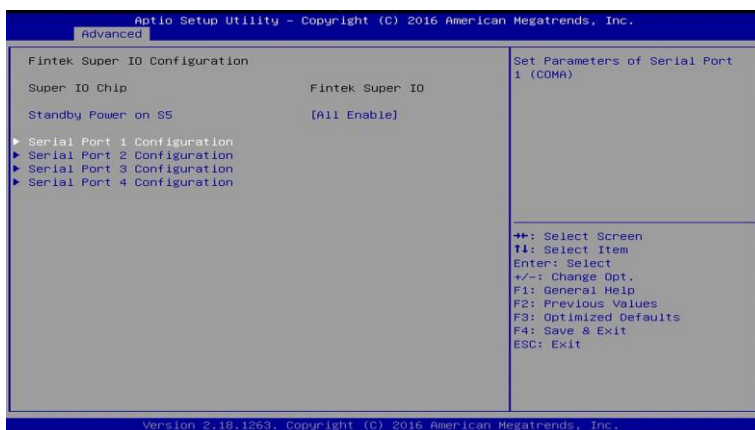

BIOS Setting	Description
Standby Power on S5	Enables / Disables to provide the standby power for devices. Options: All Enable / Enable Ethernet for WOL / All Disable
Serial Ports Configuration	Sets parameters of serial ports. Enables / Disables the serial port and select an optimal setting for the Super IO device.

4.4.3.1. Serial Port 1 Configuration

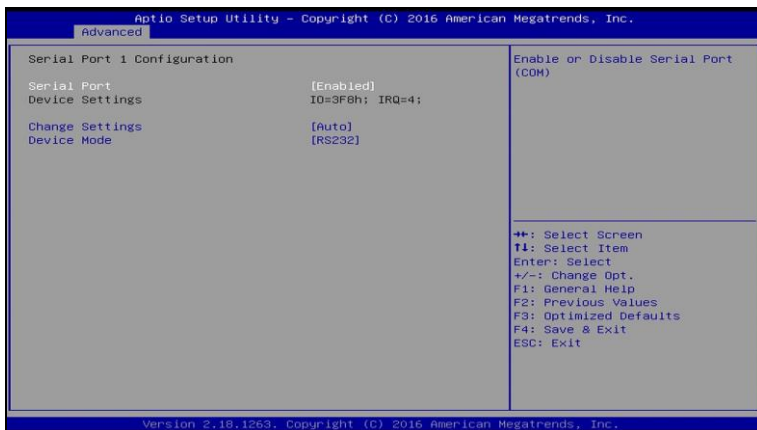

BIOS Setting	Description
Serial Port	Enables / Disables the serial port.
Change Settings	<p>Selects an optimal settings for Super IO device.</p> <p>Options:</p> <ul style="list-style-type: none"> • Auto • IO = 3F8h; IRQ = 4 • IO = 3F8h; IRQ = 3, 4, 5, 6, 7, 9, 10, 11, 12 • IO = 2F8h; IRQ = 3, 4, 5, 6, 7, 9, 10, 11, 12 • IO = 3E8h; IRQ = 3, 4, 5, 6, 7, 9, 10, 11, 12 • IO = 2E8h; IRQ = 3, 4, 5, 6, 7, 9, 10, 11, 12
Device Mode	<p>Changes the serial port mode to:</p> <ul style="list-style-type: none"> • RS232 • RS485 TX Low Active • RS485 with Termination TX Low Active • RS422 • RS422 with Termination

4.4.4 Fintek Super IO Hardware Monitor

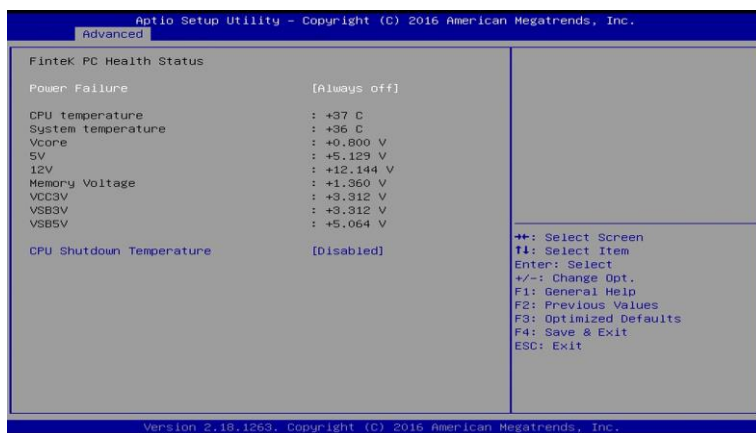

BIOS Setting	Description
Temperatures / Voltages	These fields are the parameters of the hardware monitoring function feature of the motherboard. The values are read-only values as monitored by the system and show the PC health status.
CPU Shutdown Temperature	Sets a threshold of temperature to shut down if CPU goes overheated. Options: Disabled / 70 °C / 75 °C / 80 °C / 85 °C / 90 °C / 95 °C

4.4.5 M.2 Setup

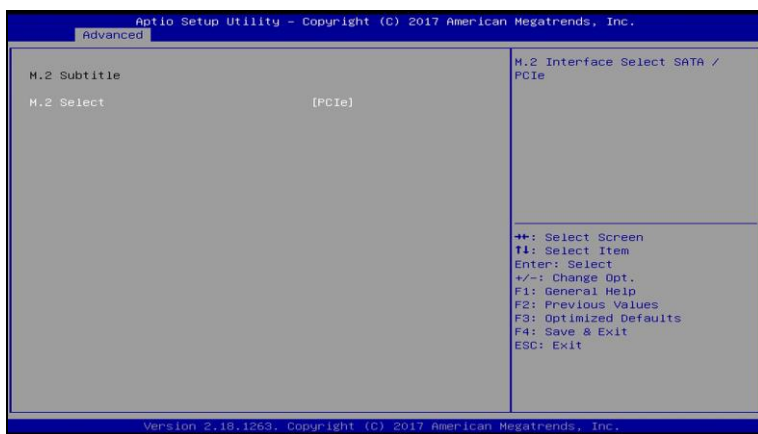

BIOS Setting	Description
M.2 Select	Selects the M.2 interface as SATA or PCIe.

4.4.6 CPU Configuration

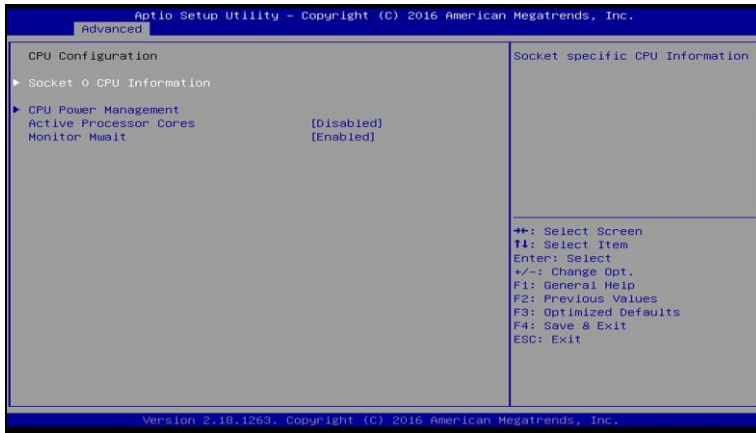

BIOS Setting	Description
Socket 0 CPU Information	Displays the socket specific CPU information.
CPU Power Management	Allows you to enable / disable Turbo Mode.
Active Processor Cores	Enables / Disables the cores in the processor package.
Monitor Mwait	Enables / Disables Monitor Mwait.

4.4.7 AMI Graphic Output Protocol Policy

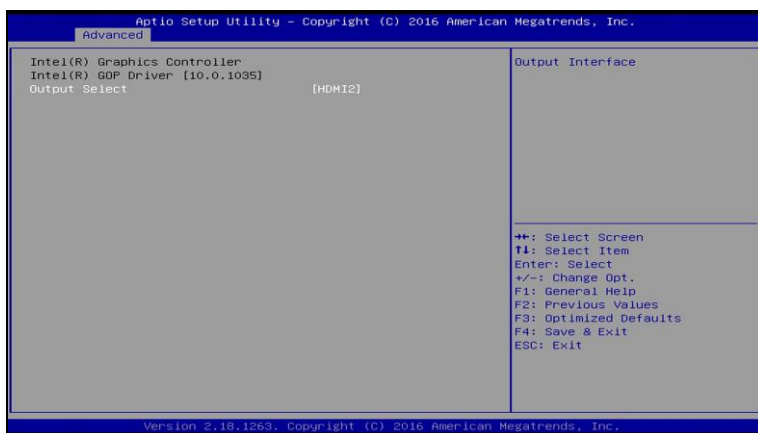

BIOS Setting	Description
Output Select	Outputs through HDMI interface.

4.4.8 Network Stack Configuration



BIOS Setting	Description
Network Stack	Enables / Disables UEFI Network Stack.
IPv4 PXE Support	Enables / Disables IPv4 PXE Boot Support. If disabled, lpv4 PXE boot option will not be created.
IPv4 HTTP Support	Enables / Disables IPv4 HTTP Boot Support. If disabled, lpv4 HTTP boot option will not be created.
IPv6 PXE Support	Enables / Disables IPv6 PXE Boot Support. If disabled, lpv4 PXE boot option will not be created.
IPv6 HTTP Support	Enables / Disables IPv6 HTTP Boot Support. If disabled, lpv4 HTTP boot option will not be created.
PXE boot wait time	Assigns a period of time to press ESC key to abort the PXE boot.
Media detect count	Assigns a number of times to check the presence of media.

4.4.9 CSM Configuration

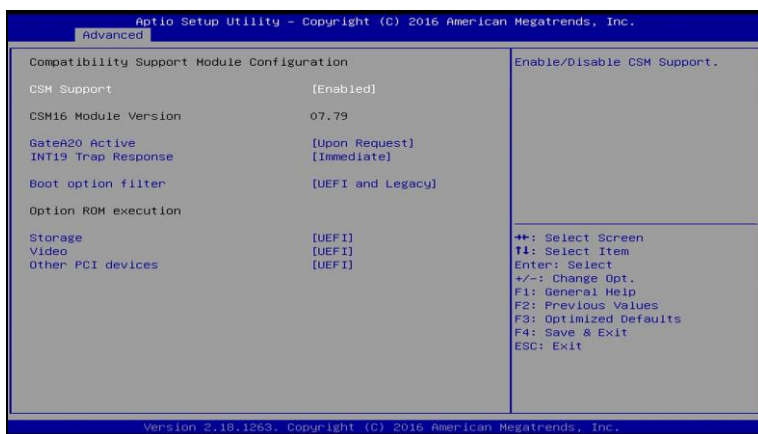

BIOS Setting	Description
CSM Support	Enables / Disables CSM support.
GateA20 Active	<ul style="list-style-type: none"> • Upon Request disables GA20 when using BIOS services. • Always cannot disable GA20, but is useful when any RT code is executed above 1 MB.
INT19 Trap Response	<p>Sets how BIOS reacts on INT19 trap by Option ROM.</p> <ul style="list-style-type: none"> • Immediate executes the trap right away. • Postponed executes the trap during legacy boot.
Boot option filter	Controls the priority of Legacy and UEFI ROMs.
Storage	Controls the execution of UEFI and Legacy Storage OpROM.
Video	Controls the execution of UEFI and Legacy Video OpROM.
Other PCI devices	Determines OpROM execution policy for devices other than network, storage or video.

4.4.10 USB Configuration

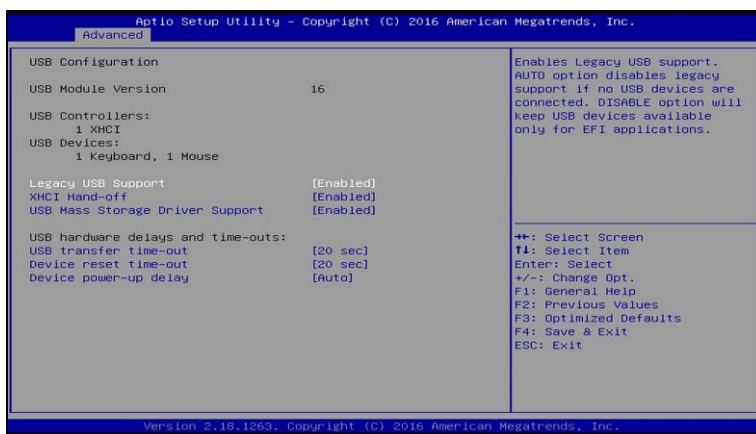

BIOS Setting	Description
Legacy USB Support	<ul style="list-style-type: none"> • Enabled enables Legacy USB support. • Auto disables legacy support if there is no USB device connected. • Disabled keeps USB devices available only for EFI applications.
XHCI Hand-off	This is a workaround for OSeS without XHCI hand-off support. The XHCI ownership change should be claimed by XHCI driver.
USB Mass Storage Driver Support	Enables / Disables the support for USB mass storage driver.
USB Transfer time-out	The time-out value (1 / 5 / 10 / 20 secs) for Control, Bulk, and Interrupt transfers.
Device reset time-out	Gives seconds (10 / 20 / 30 / 40 secs) to delay execution of Start Unit command to USB mass storage device.
Device power-up delay	<p>The maximum time the device will take before it properly reports itself to the Host Controller.</p> <p>Auto uses default value for a Root port it is 100ms. But for a Hub port, the delay is taken from Hub descriptor.</p>

4.5 Chipset Settings



4.5.1 North Bridge



BIOS Setting	Description
Max TOLUD	Sets a maximum value of TOLUD. Options: 2 / 2.25 / 2.5 / 2.75 / 3 GB

4.5.2 South Cluster Configuration

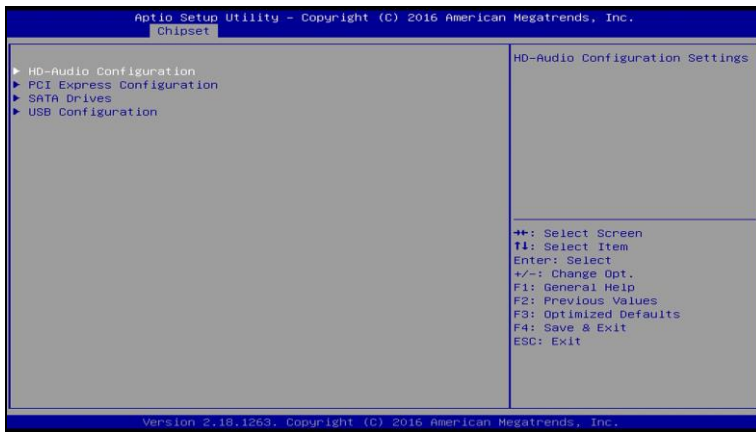

4.5.2.1 HD Audio Configuration

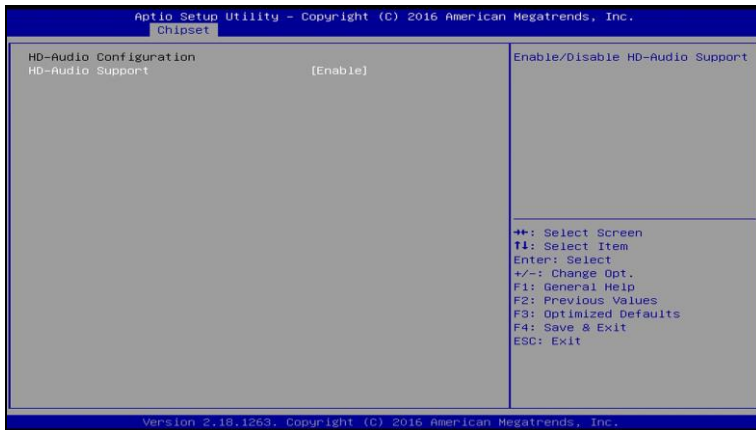

4.5.2.2. PCI Express Configuration

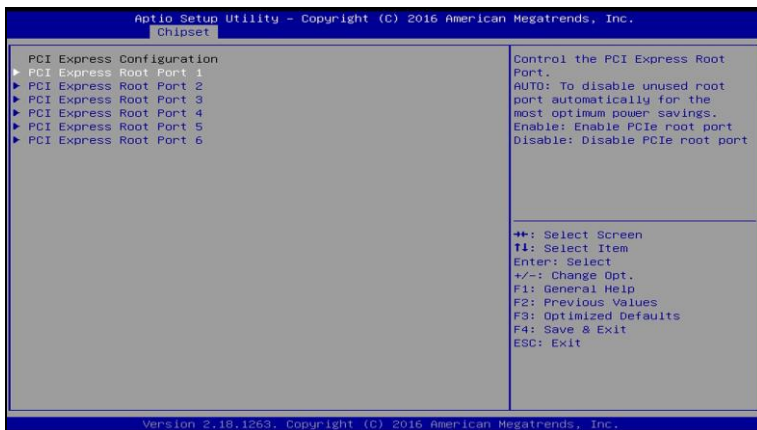

BIOS Setting	Description
PCI Express Root Port 1 ~ 6	Accesses the control of the PCI Express Root Port.

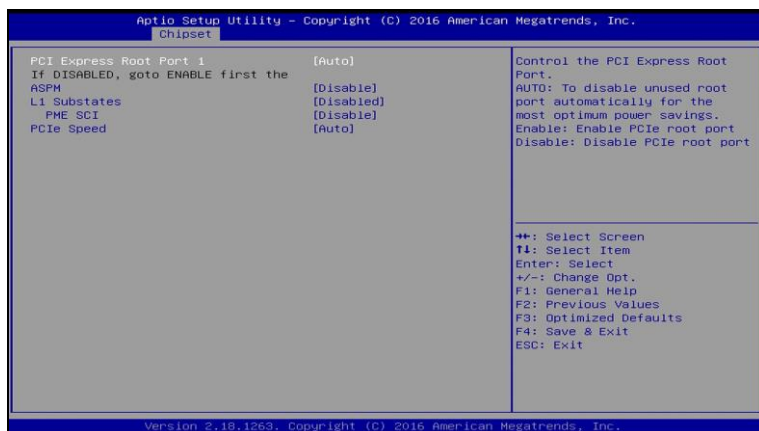

BIOS Setting	Description
PCI Express Root Port	Enables/ Disables the PCIe root port. Auto: To disable unused root port automatically for the most optimum power savings.
ASPM	Sets the PCIe active state power management. Options: Disable / L0s / L1 / L0SL1 / Auto
L1 Substates	Sets PCIe L1 substates. Options: Disables / L1.1 / L1.2 / L1.1 & L1.2
PME SCI	Enables / Disables PME SCI.
PCIe Speed	Configures the PCIe speed.

4.5.2.3. SATA Drivers

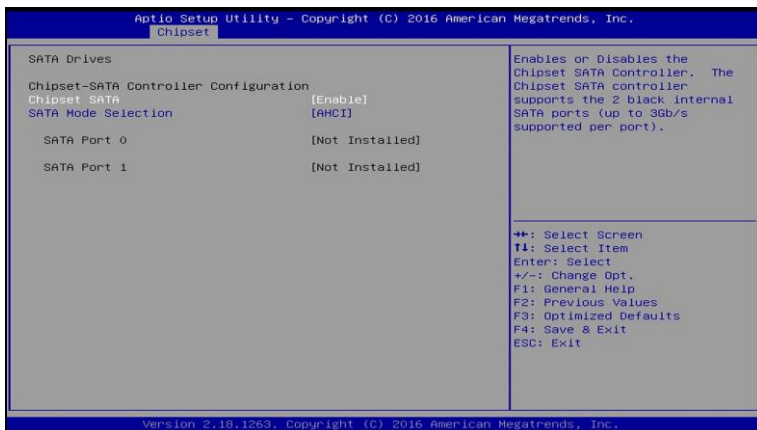

BIOS Setting	Description
Chipset SATA	Enables / Disables the Chipset SATA Controller. The Chipset SATA Controller supports the 2 black internal SATA ports (up to 3Gb/s supported per port).
SATA Mode Selection	Determines how SATA controller(s) operate.

4.5.2.4. USB Configuration

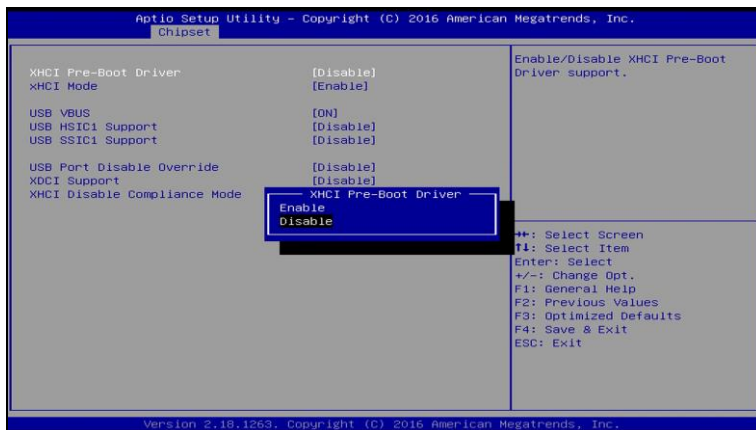

BIOS Setting	Description
XHCI Pre-Boot Driver	Enables / Disables the support for XHCI Pre-Boot Driver.
XHCI Mode	Enables / Disables XHCI mode. If disabled, XHCI controller would be disabled, and none of the USB devices are detectable or usable when system is booted up in OS. Do NOT disable it unless for debug purpose.
USB VBUS	VBUS should be ON in HOST mode. It should be OFF in OTG device mode.
USB HSIC1 Support	Enables / Disables USB HSIC1.
USB SSIC1 Support	Enables / Disables USB SSIC1.
USB Port Disable Override	Selectively enables / disables the corresponding USB port from reporting a device connection to the controller.
XDCI Support	Enables / Disables XDCI.
XHCI Disable Compliance Mode	FALSE makes the XHCI Link Compliance Mode not disabled. TRUE disables the XHCI Link Compliance Mode.

4.6 Security Settings

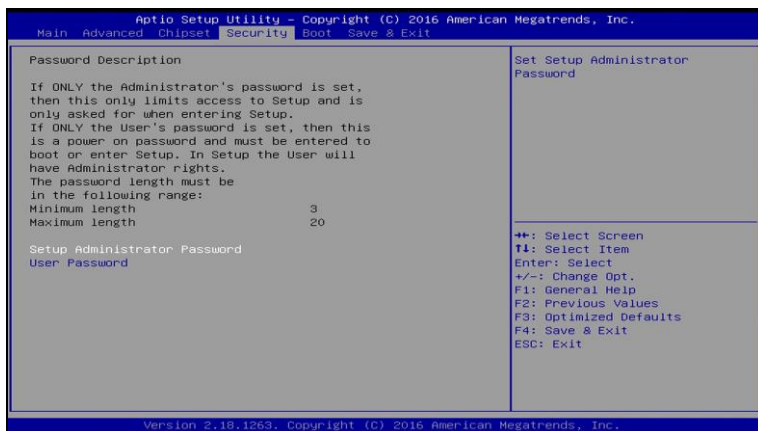

BIOS Setting	Description
Setup Administrator Password	Sets an administrator password for the setup utility.
User Password	Sets a user password.

4.7 Boot Settings

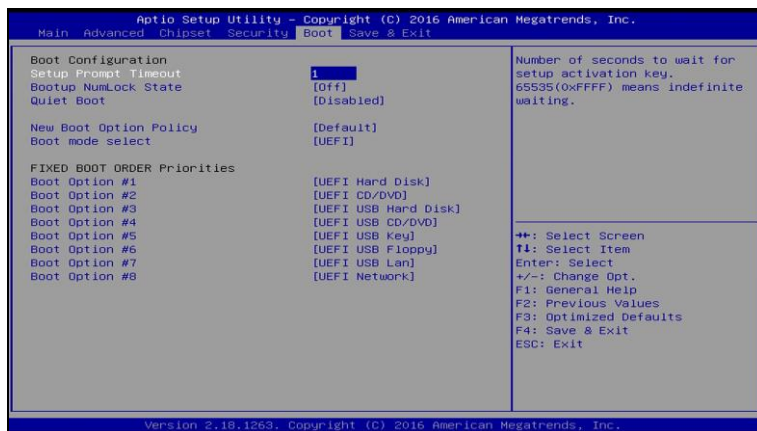

BIOS Setting	Description
Setup Prompt Timeout	Number of seconds to wait for setup activation key. 65535 (0xFFFF) means indefinite waiting.
Bootup NumLock State	Selects the keyboard NumLock state.
Quiet Boot	Enables / Disables Quiet Boot option.
New Boot Option Policy	Controls the placement of newly detected UEFI boot options. Options: Default, Place First, Place Last
Boot mode select	Selects a Boot mode, Legacy / UEFI / Dual.
Boot Option Priorities	Sets the system boot order priorities for hard disk, CD/DVD, USB, Network.

4.8 Save & Exit Settings

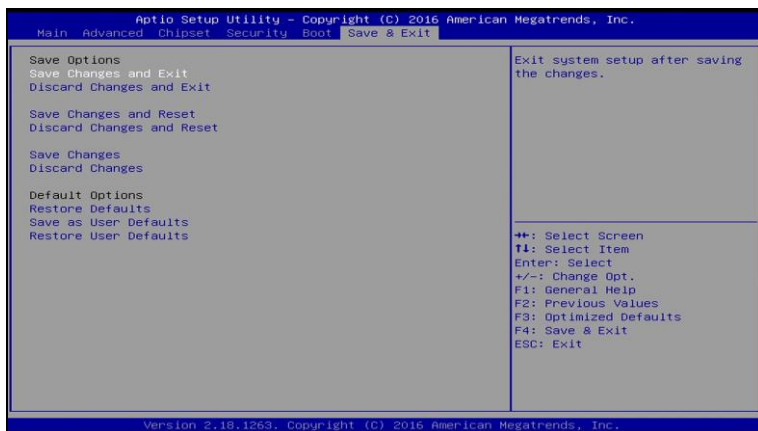

BIOS Setting	Description
Save Changes and Exit	Exits system setup after saving the changes.
Discard Changes and Exit	Exits system setup without saving any changes.
Save Changes and Reset	Resets the system after saving the changes.
Discard Changes and Reset	Resets system setup without saving any changes.
Save Changes	Saves changes done so far to any of the setup options.
Discard Changes	Discards changes done so far to any of the setup options.
Restore Defaults	Restores / Loads defaults values for all the setup options.
Save as User Defaults	Saves the changes done so far as User Defaults.
Restore User Defaults	Restores the user defaults to all the setup options.

Appendix

This section provides the mapping addresses of peripheral devices and the sample code of watchdog timer configuration.

A. I/O Port Address Map

Each peripheral device in the system is assigned a set of I/O port addresses which also becomes the identity of the device. The following table lists the I/O port addresses used.

Address	Device Description
0x0000A00-0x0000A0F	Motherboard resources
0x0000A10-0x0000A1F	Motherboard resources
0x0000A20-0x0000A2F	Motherboard resources
0x000002E-0x000002F	Motherboard resources
0x000004E-0x000004F	Motherboard resources
0x0000061-0x0000061	Motherboard resources
0x0000063-0x0000063	Motherboard resources
0x0000065-0x0000065	Motherboard resources
0x0000067-0x0000067	Motherboard resources
0x0000070-0x0000070	Motherboard resources
0x0000070-0x0000070	System CMOS/real time clock
0x0000080-0x000008F	Motherboard resources
0x0000092-0x0000092	Motherboard resources
0x00000B2-0x00000B3	Motherboard resources
0x0000680-0x000069F	Motherboard resources
0x0000400-0x000047F	Motherboard resources
0x0000500-0x00005FE	Motherboard resources
0x0000600-0x000061F	Motherboard resources
0x0000164E-0x0000164F	Motherboard resources
0x0000F040-0x0000F05F	Intel(R) Celeron(R)/Pentium(R) Processor SMBUS - 5AD4
0x0000D000-0x0000DFFF	Intel(R) Celeron(R)/Pentium(R) Processor PCI Express Root Port - 5AD9

Address	Device Description
0x000003F8-0x000003FF	Communications Port (COM1)
0x000002F8-0x000002FF	Communications Port (COM2)
0x000003E8-0x000003EF	Communications Port (COM3)
0x000002E8-0x000002EF	Communications Port (COM4)
0x0000E000-0x0000EFFF	Intel(R) Celeron(R)/Pentium(R) Processor PCI Express Root Port - 5AD8
0x00000000-0x0000006F	PCI Express Root Complex
0x00000078-0x00000CF7	PCI Express Root Complex
0x00000D00-0x0000FFFF	PCI Express Root Complex
0x00000020-0x00000021	Programmable interrupt controller
0x00000024-0x00000025	Programmable interrupt controller
0x00000028-0x00000029	Programmable interrupt controller
0x0000002C-0x0000002D	Programmable interrupt controller
0x00000030-0x00000031	Programmable interrupt controller
0x00000034-0x00000035	Programmable interrupt controller
0x00000038-0x00000039	Programmable interrupt controller
0x0000003C-0x0000003D	Programmable interrupt controller
0x000000A0-0x000000A1	Programmable interrupt controller
0x000000A4-0x000000A5	Programmable interrupt controller
0x000000A8-0x000000A9	Programmable interrupt controller
0x000000AC-0x000000AD	Programmable interrupt controller
0x000000B0-0x000000B1	Programmable interrupt controller
0x000000B4-0x000000B5	Programmable interrupt controller
0x000000B8-0x000000B9	Programmable interrupt controller
0x000000BC-0x000000BD	Programmable interrupt controller
0x000004D0-0x000004D1	Programmable interrupt controller
0x0000F000-0x0000F03F	Intel(R) HD Graphics

Address	Device Description
0x0000F090-0x0000F097	Standard SATA AHCI Controller
0x0000F080-0x0000F083	Standard SATA AHCI Controller
0x0000F060-0x0000F07F	Standard SATA AHCI Controller
0x00000040-0x00000043	System timer
0x00000050-0x00000053	System timer

B. Interrupt Request Lines (IRQ)

Peripheral devices use interrupt request lines to notify CPU for the service required. The following table shows the IRQ used by the devices on board.

Level	Function
IRQ 0	System timer
IRQ 3	Communications Port (COM2)
IRQ 4	Communications Port (COM1)
IRQ 4	PCI Data Acquisition and Signal Processing Controller
IRQ 5	Communications Port (COM3)
IRQ 5	PCI Data Acquisition and Signal Processing Controller
IRQ 6	PCI Data Acquisition and Signal Processing Controller
IRQ 7	PCI Data Acquisition and Signal Processing Controller
IRQ 8	High precision event timer
IRQ 10	Communications Port (COM4)
IRQ 14	Intel(R) Serial IO GPIO Host Controller - INT3452
IRQ 25	High Definition Audio Controller
IRQ 35	PCI Data Acquisition and Signal Processing Controller
IRQ 36	PCI Data Acquisition and Signal Processing Controller
IRQ 37	PCI Data Acquisition and Signal Processing Controller
IRQ 39	SDA Standard Compliant SD Host Controller
IRQ 54 ~ IRQ 204	Microsoft ACPI-Compliant System
IRQ 256 ~ IRQ 511	Microsoft ACPI-Compliant System
IRQ 4294967279	Intel(R) USB 3.0 eXtensible Host Controller - 1.0 (Microsoft)

Level	Function
IRQ 4294967280 ~ IRQ 4294967285	Intel(R) I211 Gigabit Network Connection #2
IRQ 4294967286 ~ IRQ 4294967291	Intel(R) I211 Gigabit Network Connection
IRQ 4294967292	Intel(R) Trusted Execution Engine Interface
IRQ 4294967293	Intel(R) HD Graphics
IRQ 4294967294	Standard SATA AHCI Controller

C. Watchdog Timer Configuration

The Watchdog Timer (WDT) is used to generate a variety of output signals after a user programmable count. The WDT is suitable for use in the prevention of system lock-up, such as when software becomes trapped in a deadlock. Under these sorts of circumstances, the timer will count to zero and the selected outputs will be driven.

Under normal circumstance, you will need to restart the WDT at regular intervals before the timer counts to zero.

Sample Code:

```
//-----
//
// THIS CODE AND INFORMATION IS PROVIDED "AS IS" WITHOUT WARRANTY OF ANY
// KIND, EITHER EXPRESSED OR IMPLIED, INCLUDING BUT NOT LIMITED TO THE
// IMPLIED WARRANTIES OF MERCHANTABILITY AND/OR FITNESS FOR A PARTICULAR
// PURPOSE.
//
//-----
#include <dos.h>
#include <conio.h>
#include <stdio.h>
#include <stdlib.h>
#include "F81964.H"
//-----
int main (int argc, char *argv[]);
void EnableWDT(int);
void DisableWDT(void);
//-----
int main (int argc, char *argv[])
{
    unsigned char bBuf;
    unsigned char bTime;
    char **endptr;

    char SIO;

    printf("Fintek 81964 watch dog program\n");
    SIO = Init_F81964();
    if (SIO == 0)
    {
        printf("Can not detect Fintek 81964, program abort.\n");
        return(1);
    }
    //if (SIO == 0)

    if (argc != 2)
    {
        printf("Parameter incorrect!!\n");
        return (1);
    }
}
```

```

bTime = strtol (argv[1], endptr, 10);
printf("System will reset after %d seconds\n", bTime);

if (bTime)
{
    EnableWDT(bTime); }
else
{
    DisableWDT();      }
return 0;
}
//-----
void EnableWDT(int interval)
{
    unsigned char bBuf;

    bBuf = Get_F81964_Reg(0x2B);
    bBuf &= (~0x20);
    Set_F81964_Reg(0x2B, bBuf);          //Enable WDTO

    Set_F81964_LD(0x07);                //switch to logic device 7
    Set_F81964_Reg(0x30, 0x01);        //enable timer

    bBuf = Get_F81964_Reg(0xF5);
    bBuf &= (~0x0F);
    bBuf |= 0x52;
    Set_F81964_Reg(0xF5, bBuf);        //count mode is second

    Set_F81964_Reg(0xF6, interval);    //set timer

    bBuf = Get_F81964_Reg(0xFA);
    bBuf |= 0x01;
    Set_F81964_Reg(0xFA, bBuf);        //enable WDTO output

    bBuf = Get_F81964_Reg(0xF5);
    bBuf |= 0x20;
    Set_F81964_Reg(0xF5, bBuf);        //start counting
}
//-----
void DisableWDT(void)
{
    unsigned char bBuf;

    Set_F81964_LD(0x07);                //switch to logic device 7

    bBuf = Get_F81964_Reg(0xFA);
    bBuf &= ~0x01;
    Set_F81964_Reg(0xFA, bBuf);        //disable WDTO output

    bBuf = Get_F81964_Reg(0xF5);
    bBuf &= ~0x20;
    bBuf |= 0x40;
    Set_F81964_Reg(0xF5, bBuf);        //disable WDT
}
//-----
//-----

```

```
//
// THIS CODE AND INFORMATION IS PROVIDED "AS IS" WITHOUT WARRANTY OF ANY
// KIND, EITHER EXPRESSED OR IMPLIED, INCLUDING BUT NOT LIMITED TO THE
// IMPLIED WARRANTIES OF MERCHANTABILITY AND/OR FITNESS FOR A PARTICULAR
// PURPOSE.
//
//-----
#include "F81964.H"
#include <dos.h>
//-----
unsigned int F81964_BASE;
void Unlock_F81964 (void);
void Lock_F81964 (void);
//-----
unsigned int Init_F81964(void)
{
    unsigned int result;
    unsigned char ucDid;

    F81964_BASE = 0x4E;
    result = F81964_BASE;

    ucDid = Get_F81964_Reg(0x20);
    if (ucDid == 0x07)                //Fintek 81964
    {
        goto Init_Finish;
    }

    F81964_BASE = 0x2E;
    result = F81964_BASE;

    ucDid = Get_F81964_Reg(0x20);
    if (ucDid == 0x07)                //Fintek 81964
    {
        goto Init_Finish;
    }

    F81964_BASE = 0x00;
    result = F81964_BASE;

Init_Finish:
    return (result);
}
//-----
void Unlock_F81964 (void)
{
    outportb(F81964_INDEX_PORT, F81964_UNLOCK);
    outportb(F81964_INDEX_PORT, F81964_UNLOCK);
}
//-----
void Lock_F81964 (void)
{
    outportb(F81964_INDEX_PORT, F81964_LOCK);
}
//-----
void Set_F81964_LD( unsigned char LD)
{
    Unlock_F81964();
    outportb(F81964_INDEX_PORT, F81964_REG_LD);
    outportb(F81964_DATA_PORT, LD);
    Lock_F81964();
}
```

```

}
//-----
void Set_F81964_Reg( unsigned char REG, unsigned char DATA)
{
    Unlock_F81964();
    outputb(F81964_INDEX_PORT, REG);
    outputb(F81964_DATA_PORT, DATA);
    Lock_F81964();
}
//-----
unsigned char Get_F81964_Reg(unsigned char REG)
{
    unsigned char Result;
    Unlock_F81964();
    outputb(F81964_INDEX_PORT, REG);
    Result = inportb(F81964_DATA_PORT);
    Lock_F81964();
    return Result;
}
//-----

//-----
//
// THIS CODE AND INFORMATION IS PROVIDED "AS IS" WITHOUT WARRANTY OF ANY
// KIND, EITHER EXPRESSED OR IMPLIED, INCLUDING BUT NOT LIMITED TO THE
// IMPLIED WARRANTIES OF MERCHANTABILITY AND/OR FITNESS FOR A PARTICULAR
// PURPOSE.
//
//-----
#ifndef F81964_H
#define F81964_H                1
//-----
#define F81964_INDEX_PORT      (F81964_BASE)
#define F81964_DATA_PORT       (F81964_BASE+1)
//-----
#define F81964_REG_LD          0x07
//-----
#define F81964_UNLOCK          0x87
#define F81964_LOCK            0xAA
//-----
unsigned int Init_F81964(void);
void Set_F81964_LD( unsigned char);
void Set_F81964_Reg( unsigned char,
unsigned char); unsigned char
Get_F81964_Reg( unsigned char);
//-----
#endif // F81964_H

```

D. Onboard Connector Reference Types

Function	Connector Name	Onboard Type	Mating Type
eDP Connector	CN1	I-PEX 20374-030E-31	I-PEX 20380-030T
LCD Backlight Connector	J2	JST B4B-PH-K-S	JST PHR-4.
LVDS Connector	J1, J3	Hirose DF20G-20DP-1V	Hirose DF20A-20DS-1C
Audio Connector	J4	Hirose DF11-12DP-2DSA	Hirose DF11-12DS-2C
USB 2.0 Connector	J6	Hirose DF11-8DP-2DSA	Hirose DF11-8DS-2C
Amplifier Connector	J7	JST B4B-PH-K-S	JST PHR-4.
SATA HDD Power Connector	J10	JST B4B-XH-A	JST XHP-4
COM2 / COM3 / COM4 RS-232 Port	J16, J17, J12	Hirose DF11-10DP-2DSA	Hirose DF11-10DS-2C
Front Panel Connector	J13	Dupon 2.54 mm-pitch pin header (Male)	Dupon 2.54 mm-pitch (Female)
Digital I/O Connector	J18	Dupon 2.00 mm-pitch pin header (Male)	Dupon 2.00 mm-pitch (Female)
DC Power Input Connector	J19	JST B2P-VH	JST VHR-2N
Backup Battery	BAT1	Molex 53047-0210	Molex 51021-0200